

PLANNING GUIDELINES FOR CAR LIFTS

PEGASOS®

- Small shaft dimensions
- Low operating costs
- Automated trip
- Car detection
- Convenient operation

CONTENTS

Product finder	3
BIM configurator	4
Lift shaft	5
Lifting height	5
Shaft width/cabin width/door width	6
Shaft depth/cabin depth	8
Headroom/cabin height/door height	10
Pit/clearing under lift	12
Internal insulation	13
Door types	15
Lift cabin	16
Switch cabinet	19
Nominal load/drive types	19
Number of trips per hour	20
Noise insulation/fire protection	21
Overview equipment options	22

COPYRIGHT AND DISCLAIMER







































The content of these planning guidelines - particularly text and graphics - are protected by copyright. Unless indicated otherwise, copyright is held by Lödige Fördertechnik GmbH. The content of this document must

not be published without the express consent of Lödige Fördertechnik GmbH.

We reserve the right to make technical changes to the planning guidelines for the PEGASOS® car lift.

PRODUCT FINDER

Which criteria are critical with regard to your car lift?
Choose from the criteria listed below.

	PEGASOS®	CARRICO®	TRAFFICO®
Low pit			
Low headroom			
Shaft width/shaft depth			
Max. door width			
Machine room			
Max. speed			
Possible number of trips per hour			
Internal insulation			
Noise emissions			
Fire protection			
Connection current values			
Operating costs			
Ease of operation			
Operation method	Hold & Run	Automatic drive	Automatic drive
Type-tested in accordance with	Machinery Directive 2006/42/EC DIN EN 81-41	Machinery Directive 2006/42/EC DIN EN 81-41	Lifts Directive 2014/33/EC DIN EN 81-20

Note on speed:

The PEGASOS® and CARRICO® car lifts are certified in accordance with Machinery Directive 2006/42/EC; in line with this, the maximum nominal speed is limited to 0.15 m/s.

Note on operation method:

The PEGASOS® is only available with the "Hold & Run" operation method.



= suitable



= well-suited



= very well-suited

BIM CONFIGURATOR

Architects and planners can immediately and easily generate the PEGASOS® car lift using the configurator. First, specify the required cabin width and depth. Decide whether you would like a pit (recommended) or a small ramp. Then specify the number of stops and entrances. The lifting height is determined by the distances between the individual floors. There are a number of door options for each entrance, enabling you to choose the best solution

for you. 2D drawings and 3D models of your configuration can be downloaded for your initial planning steps and directly incorporated into your construction plans. Several file formats are available for this purpose: 2D and 3D DWG, 2D and 3D DXF, REVIT and IFC. You can also select the scale that suits you best. We hope you enjoy your PEGASOS® car lift.

[Link to BIM configurator](#)

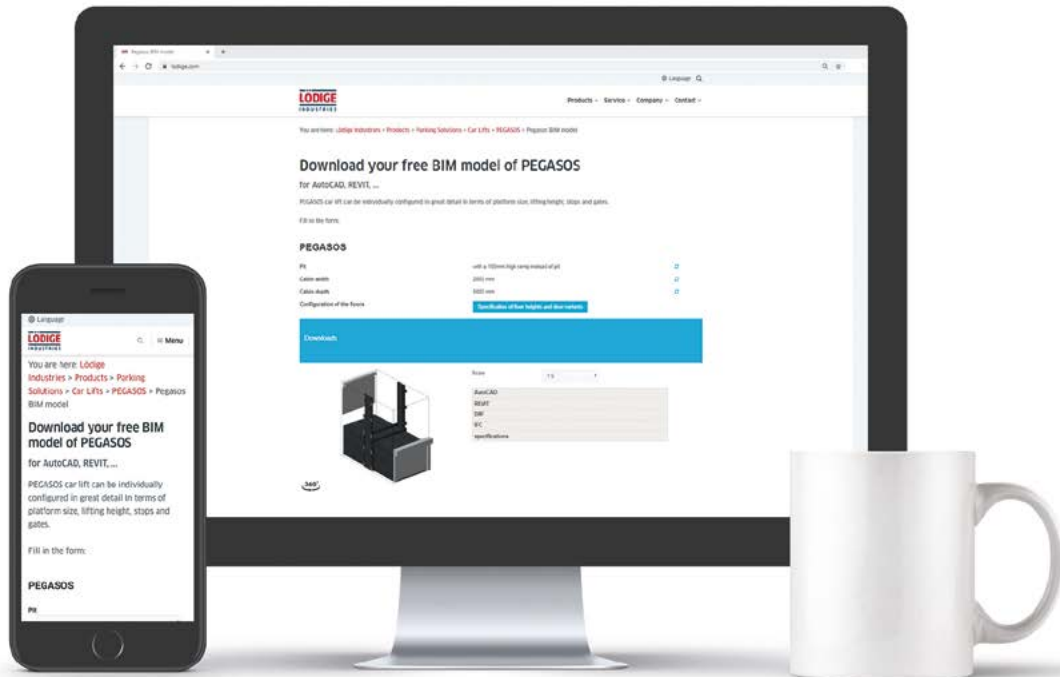

LIFT SHAFT

The lift shaft is of crucial importance with regard to planning and the technical design of the lift and must be manufactured from concrete with a minimum strength class of C 25. So that all fitted shaft components or dowels can be used correctly, the wall must be at least 150 mm thick. All requirements in relation to the structural analysis, fire protection, sound insulation and construction law must be taken into account when designing the shaft walls.

When constructing the shaft, building construction tolerances in accordance with DIN 18202 must be observed. All surfaces must be flat and level as well as right-angled and perpendicular. If, however, brickwork is used (such as existing walls), such walls must be agreed upon with us in

advance in order to establish how the lift technology is to be mounted. Any equipment not associated with the lift must not be located in the lift shaft.

All lift-related reference dimensions are explained in more detail below.

Note on niches:

Depending on the selected door variant, it may be necessary to use a niche on site. Further information on this can be found in the door variants section.

LIFTING HEIGHT

The overall distance covered by a lift is referred to as the lifting height. This is calculated from the finished floor level (FFL) of the lowest stop to the FFL of the highest stop. The lifting height is important in relation to the technical design of the lift as well as the calculation of the shaft dimensions, such as the dimensions of the pit and

headroom. The lifting height, number of stops and the layout of the entrances must be specified in order for us to prepare a quote. The maximum possible number of stops is 4 with a maximum of 8 entrances. The PEGASOS® car lift shown here features a roller door set into the wall at the lowest stop and a roller door in the headroom at the highest stop. The maximum lifting height of the PEGASOS® car lift is 24 m.

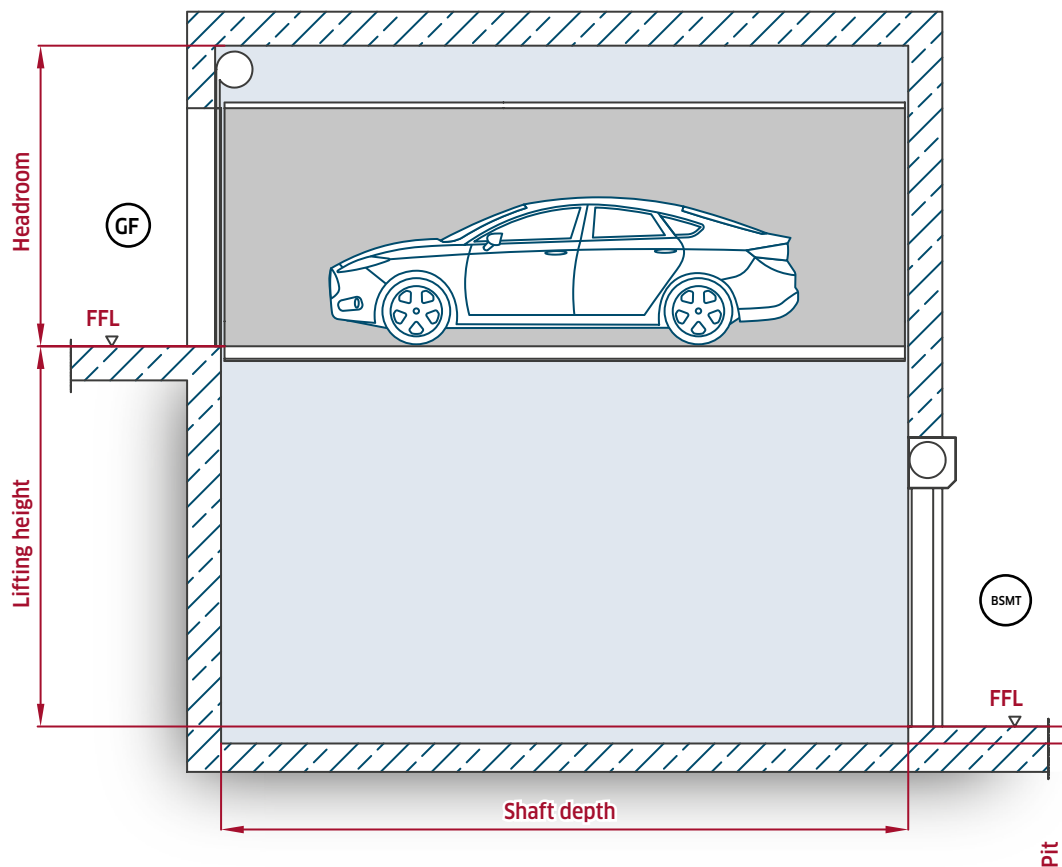

FFL = finished floor level

SHAFT WIDTH/CABIN WIDTH/DOOR WIDTH

The greater the dimensions of the cabin and doors for the car lift, the easier it is for users to safely manoeuvre their vehicle into and out of the lift cabin. The installation space available for the car lift is definitively determined by the shaft width. The shaft width is the distance between the two lateral shaft walls in the lift shaft.

In addition to the clear inner cabin width, particular emphasis is also placed on the clear inner door width, which determines the shaft width required. With regard to our PEGASOS® car lift, the door width always corresponds to the clear inner cabin width. Cabin width refers to the clear inner distance between the inner side walls of the lift cabin. The door width refers to the clear inner clearance width

of the door available when a vehicle is driven into and out of the cabin. In order for the cabin and door width for the lift system to be designed in line with the respective requirements, the vehicle-specific tractrices calculated by the planner must also be taken into account. Upon request, we can use tractrices to simulate how your specified vehicle type will enter and exit the lift cabin and determine the right lift cabin and door width for you.

In general, we can adapt the dimensions of our car lifts (width x length x height) to meet your various requirements. We are happy to develop special solutions for very long vehicles or higher vehicles, such as vans.

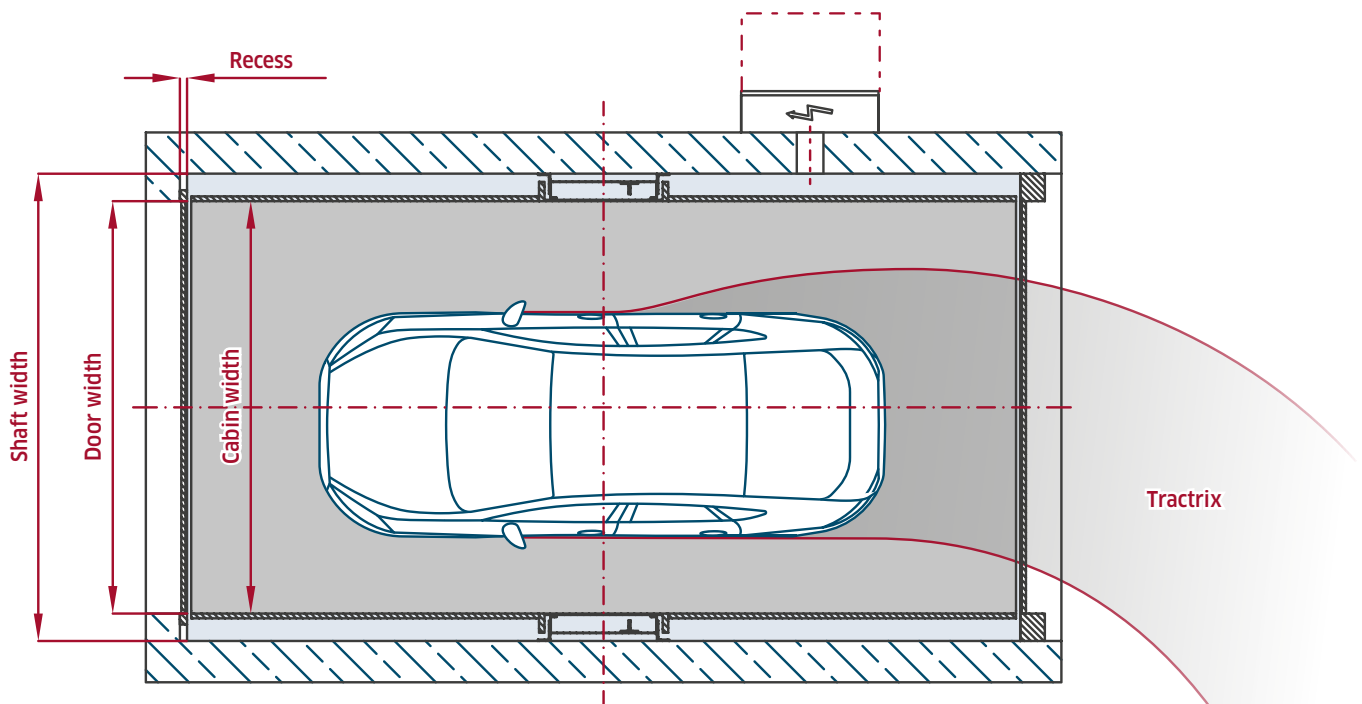

Important note regarding internal shaft insulation:

As lift shafts for car lifts are usually unheated spaces, additional internal shaft insulation can be planned for in accordance with the latest ENEC requirements (Energieeinsparverordnung - Energy Saving Ordinance) for heated rooms adjacent to the shaft. To fulfil the latest ENEC requirements, continuous insulation is required within the lift shaft. There are two options for internal shaft insulation. For more information on this, please refer to the "Internal insulation" section.

SHAFT WIDTH/CABIN WIDTH/DOOR WIDTH

During the initial steps of your planning process, you can refer to the following table, which covers common dimensions according to current information. The data applies to a maximum lifting height of 24 m. The shaft width for PEGASOS® car lifts depends on the outer shaft door and silence package selected. The silence package reduces the emitted structure-borne sound in the shaft walls.

In general, a shaft width comprising the door width plus 400 mm can be adopted for roller doors. If a silence package is selected (see the “Sound insulation” section), the width of the shaft is extended by a total of 50 mm.

As a general rule, the panelled sliding door – either with or without a silence package – requires a shaft width comprising the door width plus 600 mm, as the door runs laterally on the cabin in the shaft. The panelled sliding door complies with the requirements of the EN81-20/50 standard and is usually designed to be centrally opening, thereby reducing opening and closing times.

To simplify the process, important details, such as calculated vehicle trajectories and the width of the vehicle lane in the entrance and exit area, are not taken into account in this planning guide. To ensure that users can conveniently manoeuvre their vehicle into and out of the lift cabin without any problems, we recommend a cabin width of at least 2,800 mm.

Minimum shaft width	Maximum cabin width			Maximum door width
	Roller door without silence package	Roller door with silence package	Panelled sliding door without/with silence package*	
2,900 mm	2,500 mm	-	-	The door width always corresponds to the cabin width
2,950 mm	2,550 mm	2,500 mm	-	
3,000 mm	2,600 mm	2,550 mm	-	
3,050 mm	2,650 mm	2,600 mm	-	
3,100 mm	2,700 mm	2,650 mm	2,500 mm	
3,150 mm	2,750 mm	2,700 mm	2,550 mm	
3,200 mm	2,800 mm*	2,750 mm	2,600 mm	
3,250 mm	2,850 mm	2,800 mm*	2,650 mm	
3,300 mm	2,900 mm	2,850 mm	2,700 mm	
3,350 mm	2,950 mm	2,900 mm	2,750 mm	
3,400 mm	3,000 mm	2,950 mm	2,800 mm*	
3,450 mm	3,000 mm	3,000 mm	2,850 mm	
3,500 mm	3,000 mm	3,000 mm	2,900 mm	
3,550 mm	3,000 mm	3,000 mm	2,950 mm	
3,600 mm	3,000 mm	3,000 mm	3,000 mm	

Insulation is to be added, special designs available on request

* With regard to the panelled sliding door, the choice of silence package does not affect the shaft width.

* **Recommended minimum cabin width**

SHAFT DEPTH/CABIN DEPTH

THROUGH-LOADING/FRONT- AND REAR-OPENING DESIGN

In the case of front- and rear-opening lifts, an entrance and exit are located on opposite sides. This is the most convenient solution for users, as it significantly reduces the amount of manoeuvring required. If the construction project allows it, we therefore recommend opting for the front- and rear-opening car lift design. If a courtyard is used for bicycles, bins etc., it is possible to plan for a second access point on ground floor level.

With regard to the PEGASOS® design, the choice of door model does not affect the depth of the shaft. Since there are no cabin doors, the shaft depth corresponds to the

cabin depth plus 60 mm (distance of 30 mm per side between the cabin and front-facing shaft wall).

Cabin depth is measured from cabin edge to cabin edge and corresponds to clear inner cabin depth for PEGASOS® car lifts. Usable cabin depth is the area between the two light barriers for vehicle positioning. In order for the lift to move, the vehicle must be positioned between these two light barriers. Usable cabin depth = cabin depth - 220 mm.

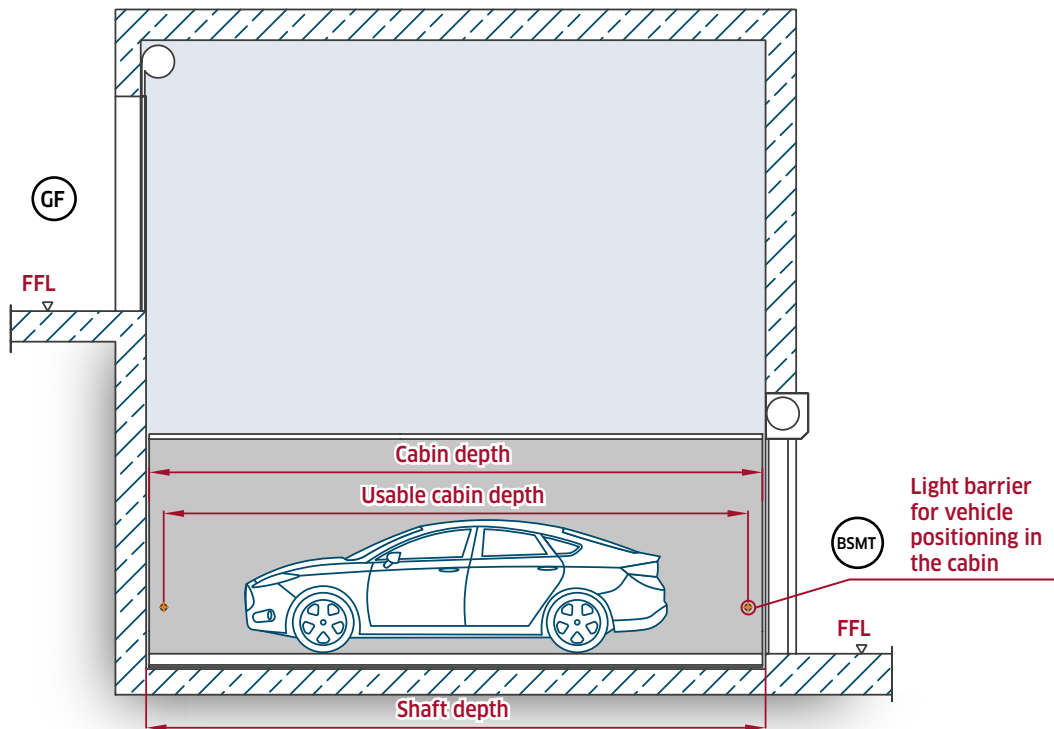

Minimum shaft depth	Maximum cabin depth	Minimum shaft depth	Maximum cabin depth
5,560 mm	5,500 mm	5,860 mm	5,800 mm
5,610 mm	5,550 mm	5,910 mm	5,850 mm
5,660 mm	5,600 mm	5,960 mm	5,900 mm
5,710 mm	5,650 mm	6,010 mm	5,950 mm
5,760 mm	5,700 mm	6,060 mm	6,000 mm
5,810 mm	5,750 mm	6,110 mm	6,050 mm

To ensure that users can conveniently manoeuvre their vehicle into and out of the lift cabin without any problems, we recommend a cabin depth of **at least 5,800 mm** and a cabin width of **at least 2,800 mm** for lifts with a front- and rear-opening design.

If desired, a maximum cabin depth of 6,400 mm is possible. In this case however, the maximum cabin width is restricted to 2,800 mm.

SHAFT DEPTH/CABIN DEPTH

FRONT-OPENING DESIGN

With regard to a front-opening lift design, the increased amount of manoeuvring required in front of the lift needs to be taken into account and efforts must be made to reduce this.

The clear inner door width (and thereby also the entrance width) must be generously set so that all users are able to reverse into and out of the cabin safely and conveniently – even with bigger vehicle classes. It is beneficial to keep the area facing the entrance of the lift in the underground car park clear for manoeuvring, as this enables users to drive directly into and out of the lift. With regard to the

PEGASOS® design, the choice of door model does not affect the depth of the shaft. With front-opening designs, the depth of the shaft is greater due to the rear wall of the lift cabin.

Cabin depth is measured from the edge of the cabin to the rear wall of the cabin. Usable cabin depth is the area between the two light barriers for vehicle positioning. In order for the lift to move, the vehicle must be positioned between these two light barriers. Usable cabin depth = cabin depth - 167 mm.

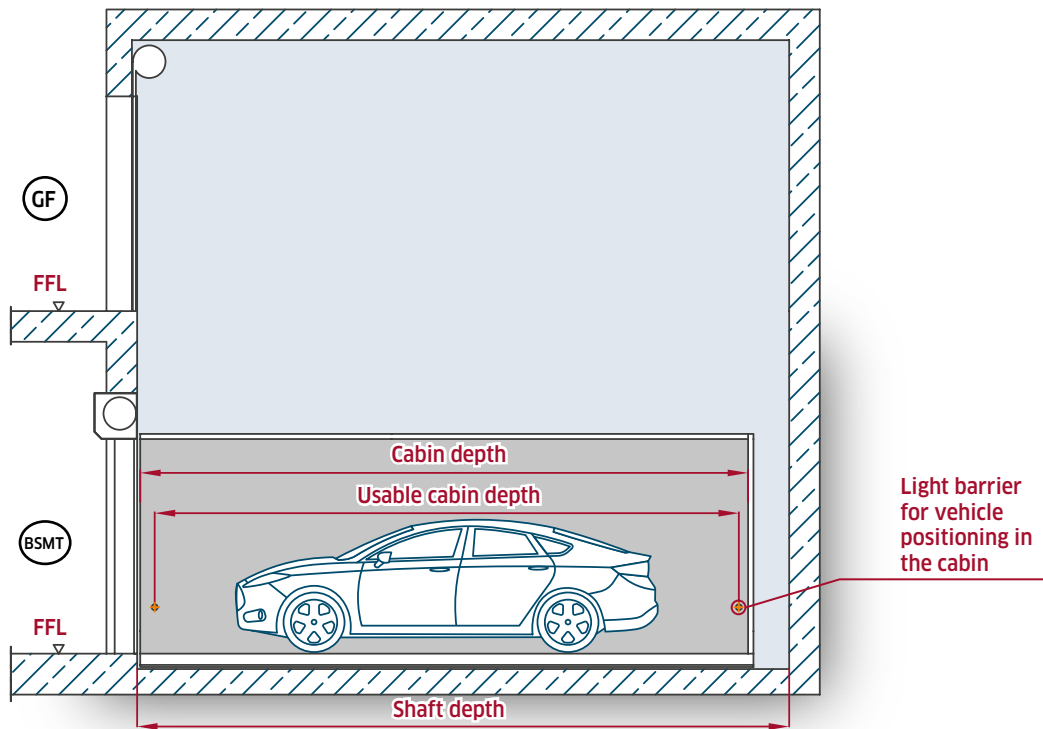

Minimum shaft depth*	Maximum cabin depth	Minimum shaft depth*	Maximum cabin depth
5,880 mm	5,500 mm	6,180 mm	5,800 mm
5,930 mm	5,550 mm	6,230 mm	5,850 mm
5,980 mm	5,600 mm	6,280 mm	5,900 mm
6,030 mm	5,650 mm	6,330 mm	5,950 mm
6,080 mm	5,700 mm	6,380 mm	6,000 mm
6,130 mm	5,750 mm	6,430 mm	6,050 mm

To ensure that users can conveniently manoeuvre their vehicle into and out of the lift cabin without any problems, we recommend a cabin depth of **at least 5,800 mm** and a cabin width of **at least 2,800 mm** for lifts with a front-opening design.

*On customer request, the rear wall in front-opening lift designs can be omitted. In this case, the design of a front-opening cabin corresponds to that of a cabin with both a front- and rear-opening design. This enables the shaft depths of the front- and rear-opening model to be implemented for a front-opening model.

HEADROOM/CABIN HEIGHT/DOOR HEIGHT

The headroom (passage) designates the distance from the finished floor level (FFL) of the highest stop to the lower edge of the shaft ceiling. The PEGASOS® car lift shown here features a roller door set into the wall at the lowest stop and a roller door in the headroom at the highest stop. With regard to the PEGASOS® car lift, the headroom dimensions

depend on the choice of door model, but not on the lifting height. In general, the clear inner door height corresponds to the clear inner cabin height. The height of the cabin is usually 2,100 mm. On customer requirement, the height of the cabin can be adapted.

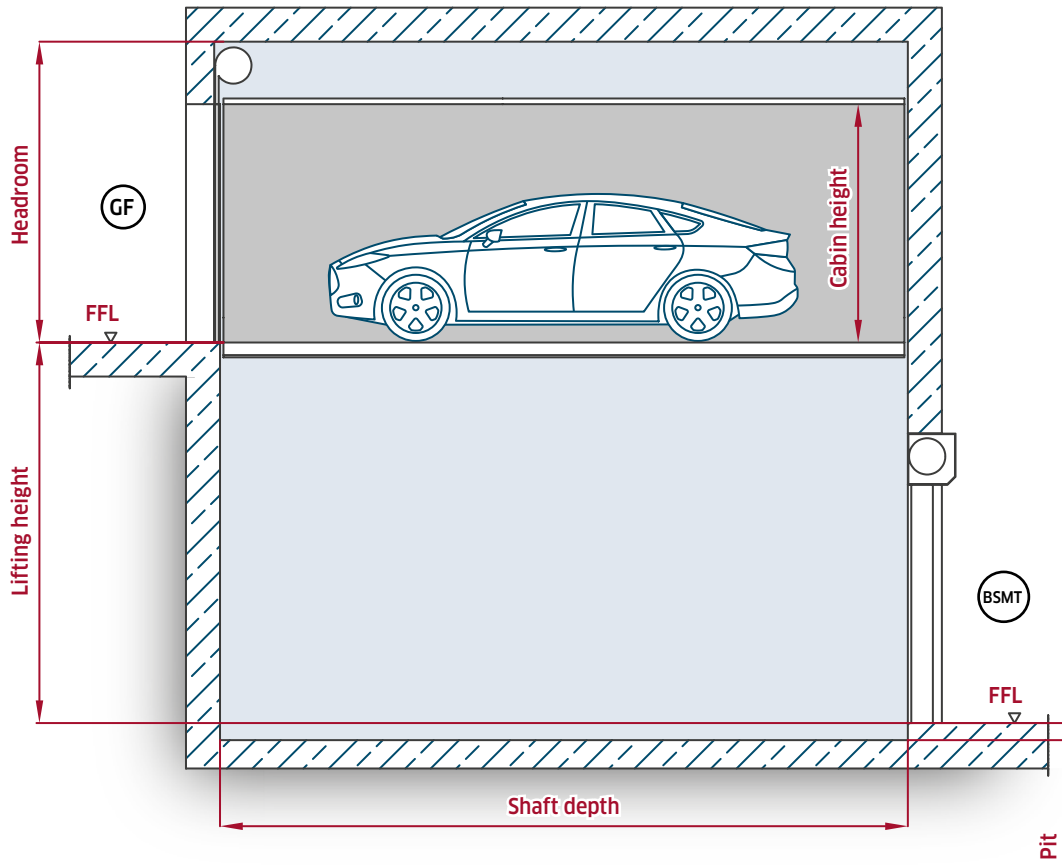

HEADROOM DIMENSIONS SUBJECT TO DOOR MODELS

In order to accommodate the lift in the building structure (e.g. penthouse), the headroom must be significantly reduced in some cases. The table below shows the minimum possible headroom dimensions subject to the door model selected at the uppermost floor based on a cabin height

of 2,100 mm as an example. You can find more information on door models in the “PEGASOS® - door models” PDF brochure, which provides additional information on the individual door designs available.

[Link to PEGASOS® door models](#)



Door model	Min. headroom with Silence Package I*	Min. headroom with Silence Package II*
Revolving door	2,550 mm	2,700 mm
Roller door in headroom	2,650 mm	2,700 mm
Roller door set into wall	2,550 mm	2,700 mm
Panelled sliding door (ELS)	2,550 mm	2,700 mm
Sectional door in headroom	2,790 mm	2,960 mm

More information about our Silence packages can be found in the section Sound insulation and options

*Silence Packages I is available in the online-configurator.

HEADROOM/CABIN HEIGHT/DOOR HEIGHT

CABIN AND DOOR HEIGHT

The standard height of the doors and cabin for car lifts is 2,100 mm. This measurement is based on the height of the car park and underground car park and is suitable for all common vehicle classes, including VW buses. If you are planning on higher vehicles, such as vans, using the lift,

then we will also gladly produce higher cabins. On customer request, the height of the cabin can be extended to 2,800 mm. If the height of the cabin and door is reduced to 2,000 mm, the headroom can also be reduced by a further 100 mm.

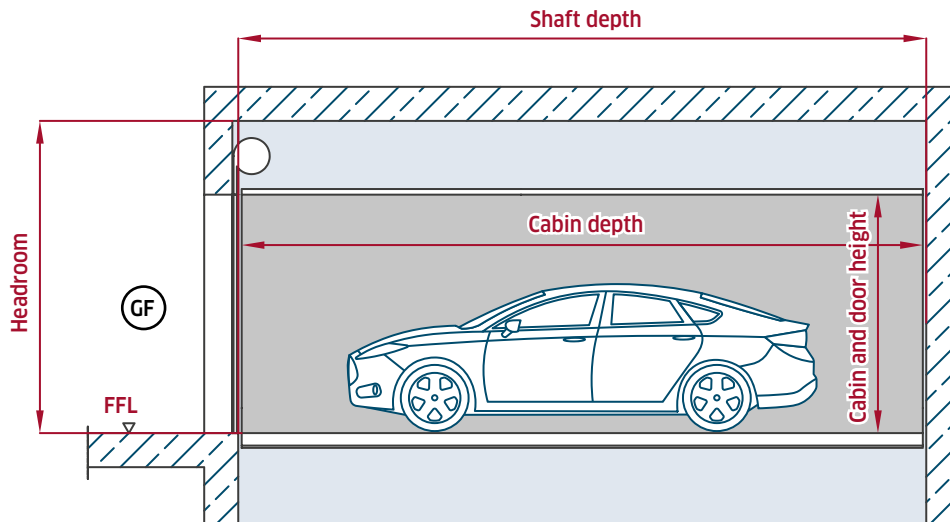

NOTE ON INSULATION

The shaft ceiling can be insulated to protect any rooms above it from a thermal bridge. If there are plans to insulate the shaft ceiling, the dimensions of the insulation must be added to the headroom dimensions. The headroom of the car lift is the smallest clear inner height, i.e.

from the FFL of the top floor to the lower edge of the shaft ceiling. If insulation is added to the shaft ceiling, the headroom height is measured from the FFL to the lower edge of the respective insulation.

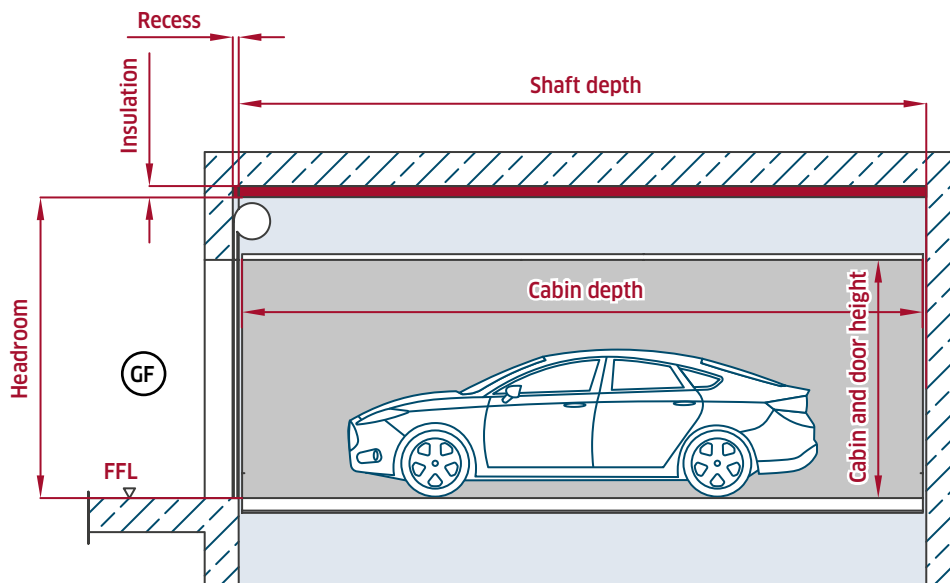

PIT/CLEARING UNDER LIFT

The pit (clearing under lift) designates the distance from the finished floor level (FFL) of the lowest stop to the upper edge of the lift shaft floor. With regard to the PEGASOS® car lift, the pit is always 150 mm. The depth of the pit does not depend on the cab size, load capacity or lifting height. Installing a 150 mm high access ramp on site makes a pit

unnecessary. For vehicles with low ground clearance, the slope of the ramp must be very large to reduce the incline of the ramp. This can make it more difficult to manoeuvre a vehicle into and out of the lift. Based on our experience, we always recommend planning for a 150 mm pit.

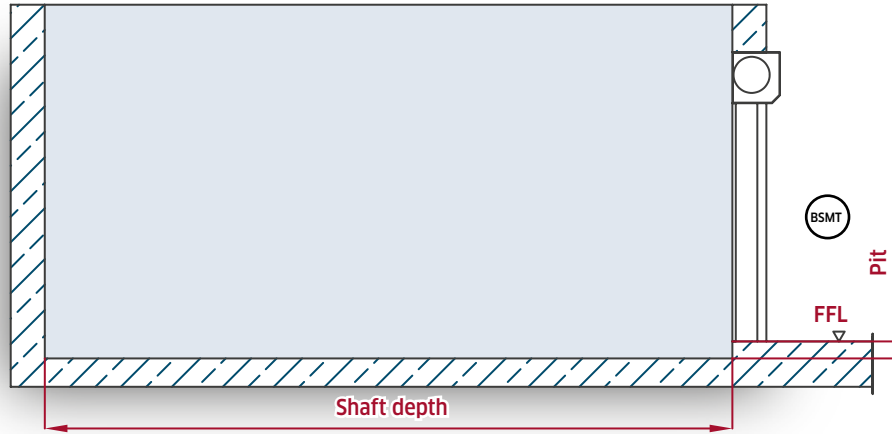

INTERNAL INSULATION

Additional internal insulation in lift shafts can be planned for in accordance with the latest ENEC requirements for heated rooms adjacent to the shaft.

Please note that you can use insulation of varying thicknesses on the various shaft walls. Doors and mounting brackets for lifting columns must always have a fixed connection to the solid shaft wall. As a rule, thermal insulation is affixed on site once the lift has been installed.

The following areas can be insulated

- Shaft side walls
- Front-facing shaft walls (except for in the area of the door)
- Shaft ceiling (headroom must always be extended by the thickness of the insulation, always omit load hooks)

INSULATION - OPTION 1 (NON-CONTINUOUS INSULATION)

If the width of the shaft is not fully extended proportional to the thickness of the insulation system, the lateral thermal insulation system is decreased in the areas of the door drives, travelling cables and lifting columns. Insulation 50–80 mm thick can be used behind the lifting columns. In this case however, the dimensional tolerance of the shaft must be taken into account, as this may reduce the thickness of the insulation.

On request, continuous insulation can be fitted in the area of the doors; a recess in the wall is required for this. The depth of the recess in the wall must correspond to the thickness of the insulation. Insulation on the front-facing shaft walls must exhibit a tensile strength of at least 300 N per 5 cm² in the entrance area with a maximum deformation of 15 mm.

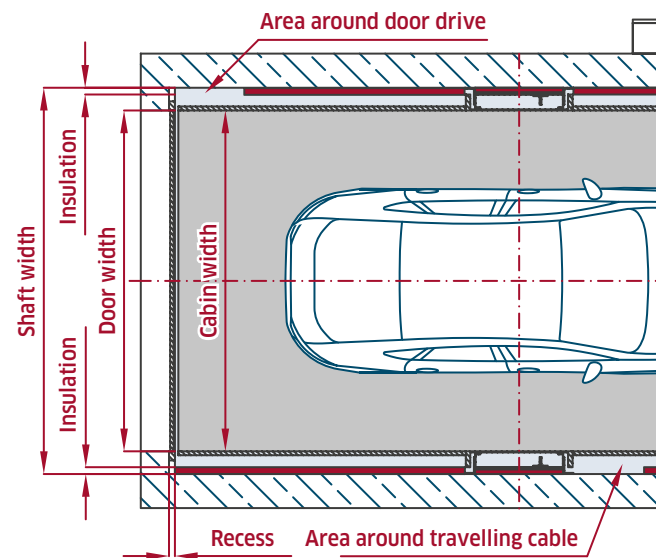

INSULATION - OPTION 2 (CONTINUOUS INSULATION)

If insulation of a uniform thickness is intended for the shaft side wall, the necessary shaft width must be extended by the thickness of the insulation fitted. If this option is selected, insulation of a uniform thickness can also be fitted behind the lifting columns. The areas around the mounting brackets and door drives on the shaft walls must remain clear.

On request, continuous insulation - as described in option 1 - can be fitted in the area of the doors.

If a panelled sliding door is used, the width of the shaft must be extended by the thickness of the insulation.

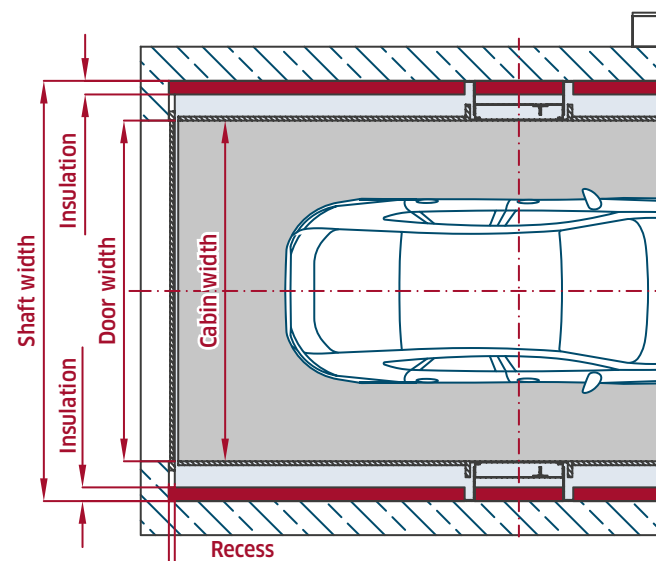

INTERNAL INSULATION



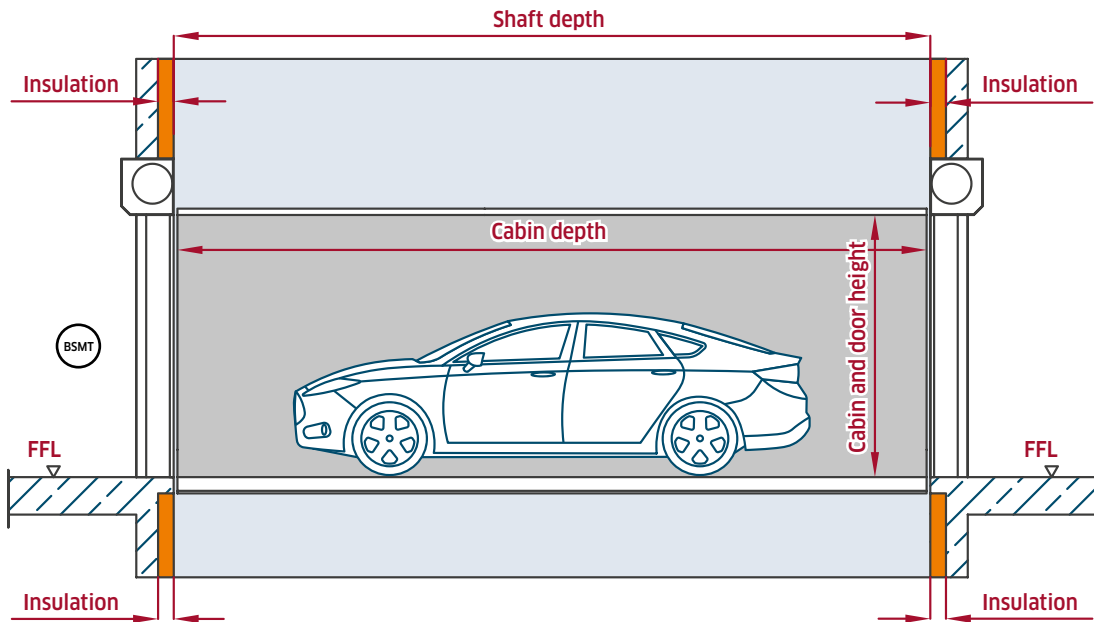
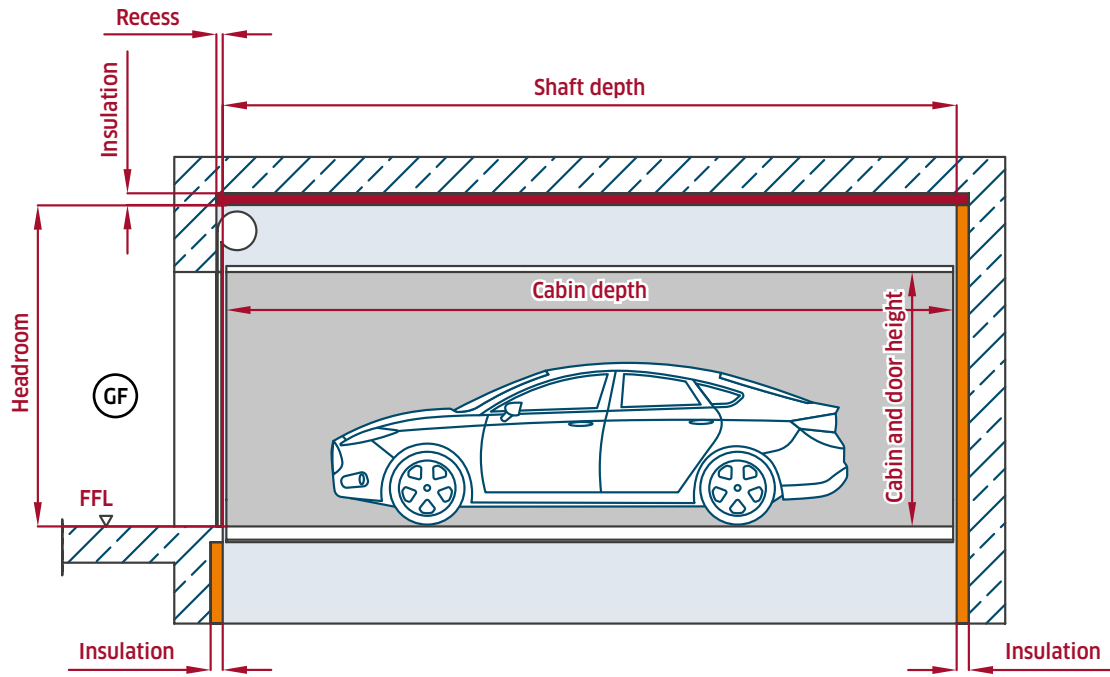



INSULATION - FIGURES APPLY TO OPTION 1 AND OPTION 2



DOOR TYPES

We currently offer six different door concepts for our PEGASOS® car lift. Our door concepts enable us to meet

your individual requirements and develop the best solution for you.

	Revolving door	Rolling shutter in the shaft head	Rolling shutter in the wall reveal	Ceiling hinge gate	Sectional door	Electric sliding door**
Door options						
Ground floor	✓	✗	✓	✓	✗	✓
Middle floors	✓	✗	✓	✓	✗	✓
Top floor (Shaft head)	✓	✓	✓	✗	✓	✓
Combined with other doors	✗	✓	✓	✓	✓	✗
Fire protection	✓	✗	✗	✗	✗	✗
Operation	Manual	Automatic Fully automatic				
Colour	RAL-Classic colours with surcharge					
Niche required	90 mm	52 mm	✗	✗	125 mm	90 mm
Silence Package III*	✗	✓	✓	✗	✗	✗
Shaft head with SPI (min.)*	2,550 mm	2,650 mm	2,550 mm	✗	2,790 mm	2,550 mm
Shaft head with SPII (min.)*	2,700 mm	2,700 mm	2,700 mm	✗	2,960 mm	2,700 mm
Shaft width with silence package*	Shaft width +50 mm (25 mm per side)			Shaft width is always cabin width + 600 mm (300 mm per side)		

*Silence package available on request

** Min. 200 mm wall depth for niche installation

✓ = possible ✗ = not possible

Opting for a sectional or roller door, either set into the wall or in the headroom, allows the entrance to the car lift to look like a simple garage. The panelled sliding door is another option. The door opens centrally, resulting in quicker closing and opening times compared to roller doors and ceiling hinged doors. The special set-up of the doors enables smooth operation as well as a hard-wearing and reliable system.

In general, any RAL colours - except metallic - can be used for our door designs. Fire protection measures cannot be

implemented for these door models.

You can find more information on door models in the "PEGASOS®-door models" PDF brochure, which provides additional information on the individual door designs available.

[Link to PEGASOS® door models](#)



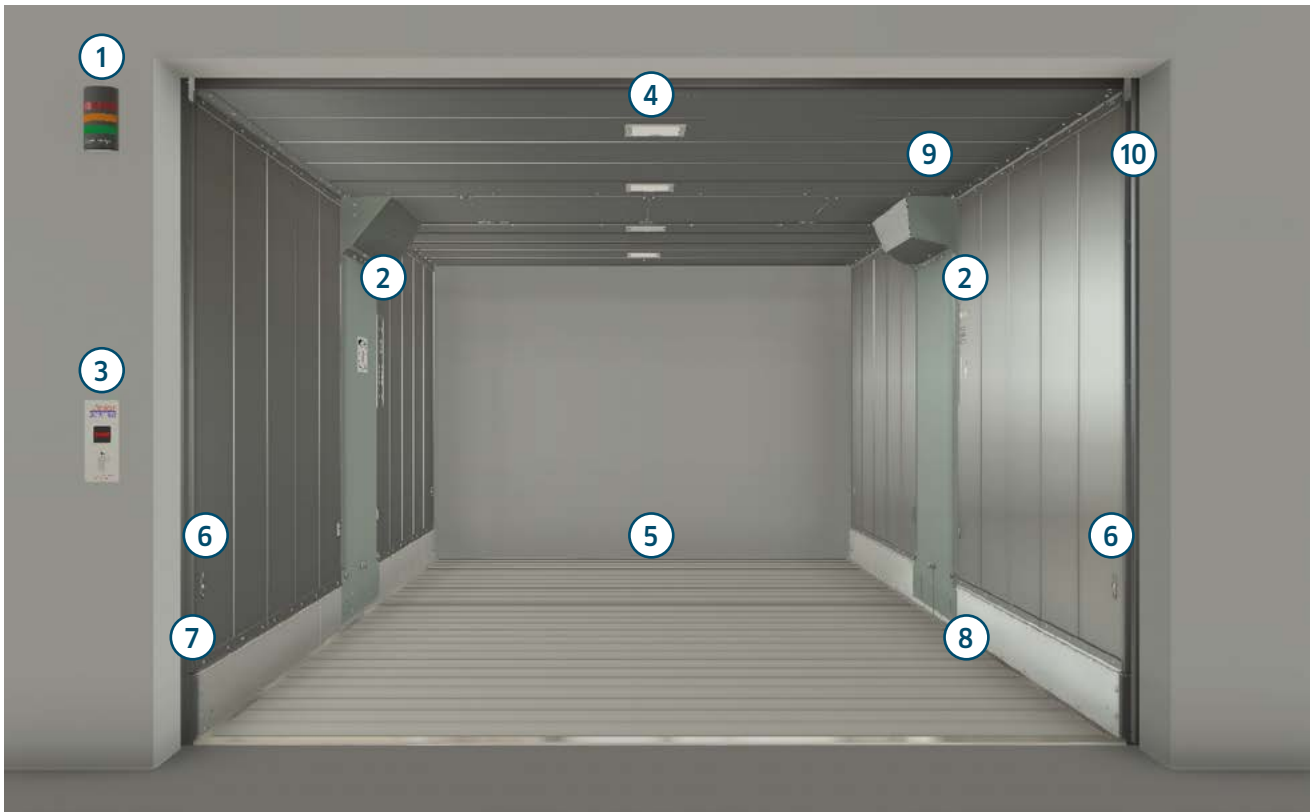

LEGEND

- | | |
|---|--|
| <ol style="list-style-type: none"> 1. Signal lights (IP65) 2. Operating panel including positioning indicator 3. Call button panel 4. LED ceiling light panel 5. Shaft wall due to front-and rear-opening design | <ol style="list-style-type: none"> 6. Light barriers for car detection 7. Light grid in entry area 8. Cabin floor and cover strips 9. Cabin ceiling/cabin walls 10. Lift door/door models |
|---|--|

1. SIGNAL LIGHTS (IP65)

The availability of the lift is simply displayed to users in colour via LED signal lights, preventing unnecessary manoeuvring and traffic disruptions. The signal lights are installed in a clearly visible position in front of the shaft doors at every stop. The traffic light has an IP protection class of IP65 and is therefore protected against the ingress of dust and water.

Meaning of the various signal lights:

All signal lights are out - lift is "ready"

Lift is stationary at parking level.
The lift can be called at any time.

Signal light flashes red - lift "occupied"

Clear the entrance area/cabin occupied.

Signal light illuminates red - lift "coming"

Cabin is empty, call is being processed.

Signal light illuminates green - "enter"

Door fully open, vehicle may enter.

LIFT CABIN

2. AND 6. OPERATING PANEL INCLUDING POSITIONING INDICATOR

As a rule, two cabin operating panels are installed in the PEGASOS® car lift. The cabin operating panels are made from stainless steel and are integrated into the side walls of the cabin. The diagonal alignment means that it is always easy for drivers to operate the panel from their vehicle.

Positioning indicators (3) are integrated into our cabin operating panels as standard. If one of the two directional arrows of the positioning indicator illuminates, the vehicle must be moved in the direction shown. If the correct position is reached, the directional arrow goes out and the "STOP" panel illuminates. The doors then close automatically and the lift travels to the stop selected by the operator.

For systems with only two stops, fully automatic travel is standard. This means that the driver does not have to select the stop; instead, the desired stop is automatically approached once the doors close. For systems with more than two stops, the lift begins to move once the floor button (4) has been selected or via a handheld transmitter.

Once the destination floor has been reached, the doors open automatically in both cases and the directional arrow pointing in the direction of the exit illuminates.

In addition, an overload indicator (1), light grid display (2), "Door open" button (5), emergency call button (6), key switch (7) [to be operated by the respective caretaker] and an emergency stop pushbutton (8) are installed as standard.



3. CALL BUTTON PANEL

In the PEGASOS® car lift, the call button panels are made of stainless steel and are always on the left-hand side of the door.

If the lift can be accessed from outdoors, the function of the call button is replaced by a key switch (2). It is also possible to call the lift via handheld transmitters functioning as a wireless remote control system, ceiling pull switches or operator consoles on the respective parking levels. The light field (1) shows the status of the elevator. If the elevator is used and is therefore not available, this is indicated by means of "occupied" in the light field.



LIFT CABIN

4. LED CEILING LIGHT PANEL

Square, energy-saving LED panels are installed in our car lifts as standard. The LED panels in the cabin ceiling ensure high-quality, long-lasting illumination. In addition, the LEDs reduce energy consumption and have a service

life ten times longer than that of conventional fluorescent lamps. The light is 840 neutral white and the colour temperature is 4,000 K. Each LED panel has an output of 18 W and a light current of 1,200 lm.

6. LIGHT BARRIERS FOR CAR DETECTION

The light barriers detect the exact position of the vehicle. The positioning display (see point 2. *Cabin panel incl.*

positioning display) guides in the correct position with directional arrows.

7. LIGHT GRID IN ENTRY AREA

Since there are no cabin doors, safety light grids are fitted in the area of the doors along the full height of the cabin

in the PEGASOS® car lift; these light grids immediately stop the car lift once they are activated.

8. CABIN FLOOR

The cabin floor of the PEGASOS® car lift comprises extruded aluminium sections with a transversely profiled surface. Using aluminium profiles for the cabin floor as well

as skirting and a cabin sill made of stainless steel ensures effective corrosion protection.

9. CABIN CEILING/CABIN WALLS

The cabin walls and cabin ceiling are manufactured from Sendzimir-galvanised sheet steel and are constructed using a lamellar construction method. The structure and

Sendzimir galvanisation process offer adequate protection against weather conditions. The walls and ceiling can also be painted on customer request.

10. LIFT DOOR/DOOR MODELS

We currently offer five different door concepts for our PEGASOS® car lift. Our door concepts enable us to meet your individual requirements and develop the best solution for you.

You can find more information in the section on door models as well as the “PEGASOS® - door models” PDF brochure, which provides additional information on the individual door designs available.

SWITCH CABINET

The PEGASOS® car lift does not require a separate machine room. A switch cabinet is used as standard. Only electrical components and the lift control system are integrated into the switch cabinet. The two electric motors for the PEGASOS® lift are installed on the roof of the cabin.

As a rule, the switch cabinet is to be located adjacent to the lift shaft. The switch cabinet and lift shaft are connected via electrical lines, which can be routed through a wall opening and empty conduit with a diameter of 125 mm. Alternatively, it is also possible for the switch cabinet to

be located up to 12 m from the lift shaft – preferably within sight of the lower door.

The dimensions of the switch cabinet are always the same for PEGASOS® car lifts and are (W x H x D) 1,000 mm x 2,100 mm x 300 mm. A 700-mm-deep free zone or work area the same width as the switch cabinet must be included in front of the switch cabinet.

NOMINAL LOAD/DRIVE TYPES

Our electrical PEGASOS® car lift is designed for a nominal load of up to 3,100 kg as standard. The lift is primarily approved for the transportation of passenger cars with/without passengers. The maximum axle load is set to 1,750 kg.

The cabin can, of course, also be used for transporting rubbish containers or bicycles, for example (to be managed by the respective caretaker). To this end, the key switch in the operating panel must be activated and the respective floor button (inching mode) pushed.

Larger cabins and nominal loads up to 3,500 kg are always possible on request. In the standard design, the electrical drives are run with a cost-effective frequency converter (restriction of start-up currents) and operate with the current values shown as guide values in the table. The current data specified in the table must be taken into account in advance when calculating the power requirement for rating the service connections.

Based on the type test, the nominal speed of the PEGASOS® car lift is limited to maximum 0.15 m/s.

Sizes of drives for the PEGASOS® car lift

Lifting height	Speed	Rated output	Nominal current	Rated fuse current
up to 24,000 mm	0.15 m/s	8 KW	17 A	25 A

*Special designs available on request, technical changes possible, PEGASOS® always 0.15 m/s, cabin 6.0 m x 3.0 m

NUMBER OF TRIPS PER HOUR

The number of trips results from the travel time, the door running times and the time taken for a vehicle to enter and exit the cabin. However, the actual number of vehicles that can be moved in a direction of travel per hour per lift system depends on a wide range of factors. The key factors that have a significant impact on the number of trips per hour are the lifting height, nominal speed and number of stops. For the PEGASOS® car lift, the choice of door model also has a significant impact on the number of trips. Other influencing factors include vehicle tracterices on entry and exit, the clear inner cabin and door widths and repeated use of the lift by a group of users in contrast to those who use the lift only once.

Automatic vehicle detection and thereby automatic lift travel (only if there are two stops) is hugely convenient and has a positive impact on the number of trips. Whether the car lift is equipped with doors on both sides – a front- and rear-opening design – or whether users have to reverse out of a front-opening lift also plays a role.

Several car lifts operated via a group control system enables the volume of traffic in one direction of travel to be handled much more efficiently.

If you would like to optimise your traffic analysis, please get in touch.

CYCLE TIMES - PEGASOS® WITH ROLLER DOORS

Lifting height in mm	Speed m/s	Door opening times in s	Door closing times in s	Pure travel time in s	Entering/leaving the cabin in s	Total cycle time in s	Vehicles per hour
3,000	0.15	↑ 16 ↓	↑ 16 ↓	24	↑ every 15 ↓	142	25
6,000	0.15			44		182	19
9,000	0.15			64		222	16
24,000	0.15			164		422	9

Basis for calculation: nominal load 3,100 kg, door width 2.8 m, front- and rear-opening design, two stops

CYCLE TIMES - PEGASOS® WITH PANELLED SLIDING DOOR

Lifting height in mm	Speed m/s	Door opening times in s	Door closing times in s	Pure travel time in s	Entering/leaving the cabin in s	Total cycle time in s	Vehicles per hour
3,000	0.15	↑ 5 ↓	↑ 7 ↓	24	↑ every 15 ↓	102	35
6,000	0.15			44		142	25
9,000	0.15			64		182	20
24,000	0.15			164		382	9

Basis for calculation: nominal load 3,100 kg, door width 2.8 m, front- and rear-opening design, two stops

Calculating “total cycle time” and “vehicles per hour”: The values specified apply to the transportation of a vehicle in one direction of travel based on average empirical values. User profiles can vary.

A cycle is defined as follows: lift door opens – vehicle enters (approx. 15 s) – lift door closes – lift travels to uppermost stop (ground floor) – lift door opens – vehicle exits (approx. 15 s) – lift door closes – lift travels back to undermost stop (basement) – lift ready for next vehicle.

NOISE INSULATION / FIRE PROTECTION

In order to protect the occupants from health hazards, the legislator has laid down the minimum requirements for sound insulation in buildings in DIN 4109 with exact decibel values for each type of building and room. In addition, VDI Guideline 4100 applies to building construction; it specifies sound insulation levels from normal to high comfort requirements in residential buildings. When lifts are operated, noise is generated that is introduced into the building as airborne and structure-borne sound. We will be happy to support you and your building physics planner as early as the planning phase in order to coordinate the topic of sound insulation with you. In order to achieve the limit values for adjacent rooms requiring protection, measures must be taken on the building side to reduce the propagation of noise, e.g. through optimised floor plans or double-shell construction. In order to provide you with the best possible support in reducing airborne and structure-borne noise, we offer you several Silence Packages. The use of our Silence Packages can support the effect of on-site measures. The use of the Silence packages can have an effect on the required shaft geometries (e.g. increased shaft width and shaft head).

SILENCE PACKAGE I - MEGI - RAILS

This includes vibration-damping rubber-metal elements that are placed between the building and the machine.

SILENCE PACKAGE II - SELF SUPPORTING PORTAL

This includes a self-supporting lift technology. The self-supporting steel portal is doweled directly to the shaft base of the shaft. The loading supports in the upper area on the shaft walls are used for the „loading“ load case and the load case „catching“.

SILENCE PACKAGE III - INSULATING ELEMENTS FOR ROLLER SHUTTER DOORS

This includes vibration damping sylomer elements, specially developed for use in our roller doors. The vibration damping sylomer elements will be placed between the drive unit of the roller shutter and the fastening and the fastening elements on the building.

For further information and recommendations effects on the structural dimensions, can be found in the following Options section below.

In general, the car lift can be installed in fire-resistant shafts according to DIN 4102. Our swing doors meet the requirements of DIN EN 81 - 58. For all other door variants, an upstream fire door must be provided on site.

Furthermore, the Pegasos car lift is equipped with a static fire control system. This means that the elevator drives directly to a previously defined evacuation stop and remains there with the doors open. The command comes from an on-site fire alarm system.

SILENCE PACKAGE I - MEGI - RAILS

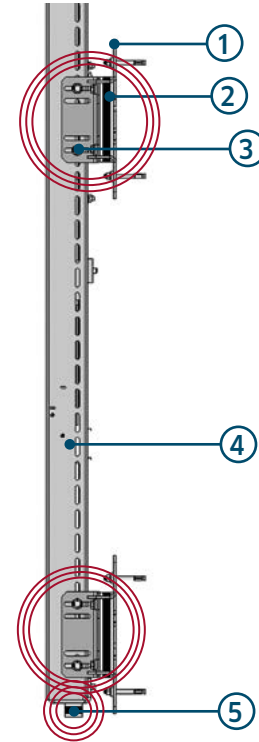

- 1.Spacer bracket
- 2.MEGI-Rail between spacer bracket and retaining bracket
- 3.Retaining bracket
- 4.Lifting column
- 5.MEGI-Rail between lifting column and pit

SILENCE PACKAGE II - SELF-SUPPORTING PORTAL

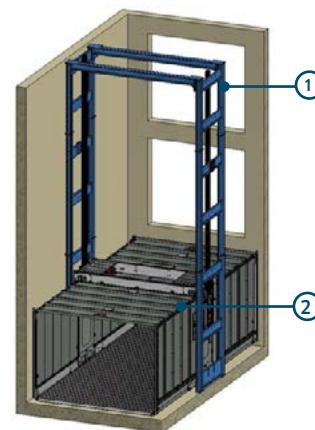

1. Self-supporting portal
2. Cabin

OVERVIEW OPTIONS

Various additional options are available for our PEGASOS® car lift. If you have any further wishes regarding the equipment, please contact us.

SOUND INSULATION

By using our Silence Packages, the on-site measures can be supported in their effect.

Silence Package I – MEGI – Rails

Package I include vibration-damping rubber-metal elements that are placed between the building and the machine. The elements reduce structure-borne noise from the machine in operation. They are maintenance-free and resistant to corrosion.

- Min. shaft width = cabin width + 450 mm
- Min. shaft head height = 2,550 - 2,790 mm (depending on selected door)
- Max. lifting height 24,000 mm

Our application recommendation:

- For double-shell shaft construction with common shaft pit.
- Decoupled shaft head cover (contact surface on outer shaft shell/wall)
- In combination with Silence Package III

Silence Package II – Self-supporting portal

The Silence Package II includes self-supporting lift technology. The self-supporting steel portal, Silence Package 2, is doweled directly to the shaft pit bottom. The loading supports in the upper area on the shaft walls are used for the load case “loading” and the load case “catching”. Adjustable buffer elements with structure-borne sound effect are used here as emergency stops. In normal driving operation, all forces and vibrations are primarily transmitted to the pit bottom, with centric loading.

The following structural dimensions must be taken into account when selecting the Silence Package II:

- Min. shaft width = cabin width + 450 mm
- Min. shaft head height = 2.700 - 2.960 mm (depending on selected door)
- Max. lifting height 6.000 mm

Our application recommendation:

- For single-shell shaft construction
- If rooms requiring protection are directly adjacent to the lift shaft
- Thickness of the shaft pit base 500 mm
- In combination with Silence Package III

Silence Package III – Insulating elements for roller shutters doors

Package III includes vibration damping Sylomer elements, specially developed for use with our roller doors, which are placed between the drive unit of the roller doors and the fastening elements on the building. The elements reduce the structure-borne noise from the roller shutter in operation and reduce the airborne noise emission in the adjacent rooms of the lift shaft. They are maintenance-free and resistant to corrosion. This option can be selected for the door variants roller shutter in the shaft head and roller shutter in the wall reveal and has no effect on structural dimensions.

Note on sound emissions:

We expressly point out that even with the installation of our Silence Package, the sound pressure level LAF max ≤ 30dB(A) required in accordance with DIN 4109 for residential rooms requiring protection is currently not achieved with single-shell construction of the shaft masonry. Architects and shell construction contractors must ensure compliance with the relevant guidelines and standards, e.g. DIN 4109.

In order to achieve increased sound protection for e.g. rooms requiring protection, we recommend a double-shell construction of the lift shaft to prevent structure-borne sound transmission.

OVERVIEW OPTIONS

OPERATION:

Hand-held transmitter Radio remote control

The control system of the Pegasos is additionally equipped with a radio remote control. The radio remote control can be carried directly in the car. The user can request the lift without having to leave the car.

*) max. cable length 10 m, cable length: 2m. If special fixings are required due to the construction situation, these must be provided by the customer.

App - Control

With our smartphone app solution users can call and operate car lifts via smartphone. The integrated administration tool lets you easily add or manage users and restrict or grant access saving time and cost. Up to 1,000 users can be created per elevator. As a completely Bluetooth-based system, the app works independently of any internet connection. Ranges of up to 30 meters from the elevator doors are possible with the app.

[Link to the smartphone app](#)



PLANNING:

Creation of the factory planning

At the customer's request, a factory planning of the installation can be prepared before the main order is placed. This includes all relevant information for the implementation of the project or the installation of the system and a schematic representation of the lift shaft with all lift components located in the shaft. We generally recommend that you have a construction plan drawn up at an early stage of your project.

The big advantage:

All relevant information/requirements for the installation and operation of the lift are clarified. The costs of the works planning are credited back to you in full when the main order is placed.

The following points are considered/shown in the standard work planning:

- Schematic representation of the lift shaft,
- Switch cabinet at the shaft
- All lift components located in the shaft
- If applicable, consideration of thermal insulation in the shaft
- Load hook
- Door openings and doors
- Verbal reference to shaft smoke extraction
- Installation scaffolding
- Effective forces
- Electrical connection values

INSTALLATION:

Load hooks for dowelling

The use of load hooks is always required for the assembly of the car lift. On request, we supply 2 load hooks for dowelling with rope eyelet incl. delivery and assembly and consideration of the acting forces from the factory planning.

Assembly scaffolding

The use of assembly scaffolding is always necessary for the assembly of the car lift. On request, we can supply you with the required assembly scaffolding with scaffolding shoes for dowelling for one scaffolding level each, including delivery, assembly, dismantling and removal.

OVERVIEW OPTIONS

SERVICE:

Standard maintenance lift system

- Maintenance frequency: according to manufacturer's specifications (2x or 4x per year).
- According to DIN13015.
- Test of safety functions and system functions, adjustment work, lubrication maintenance and cleaning of operational contamination.

Full maintenance of lift system

- Maintenance frequency: according to manufacturer's specifications (2x or 4x per year)
- According to DIN13015
- Test of safety functions and system functions, adjustment work, lubrication maintenance and cleaning of operational contamination.
- Spare parts and repair service (only for reasons for which Lödige is responsible)
- Option for warranty extension

ADDITIONAL OPTIONS:

Colour coating of roller shutter slats

The colour coating of the roller shutter slats can be carried out in the common Classic RAL colour shades according to the customer's wishes.

Key safe

In case of an emergency, accessibility to the system must be ensured, especially in case of personal rescue. A key safe is required for this purpose. On request, we offer a complete key safe with 3 keys, security card: Series 600 834 EFEFBF and wall anchor.

- Outer dimensions: 145 x 46 mm
- Internal dimensions: 78 x 36 mm

The key safe is installed on site by the customer. A core hole should be drilled for the installation during planning.

Lödige (United Kingdom) Ltd.
Laxton House | Crabtree Office Village | Eversley Way
TW20 8RY Egham, Surrey
United Kingdom

Tel. +44 1784 221140
Fax +44 1784 471425
uk@lodige.com

www.lodige.co.uk

