

## PLANNING GUIDELINES FOR GOODS LIFTS

### SHERPA® and ESCORTA®

- Goods lifts planning made easy
- Understanding and applying shaft dimensions
- Dimensioning pits and ramps correctly

## CONTENTS

---

Product finder	3
Product description	4
Application areas	5
BIM-Configurator	6
Load capacity	6
Lift shaft	7
Lifting height	8
Shaft width/cabin width/door width	9
Shaft depth/cabin depth	10
Shaft head/cabin- and door height	11
Pit/ramp	12
Shaft doors/fire protection	13
Lift cabin	14
Control cabinet	18
Drive type	19
Lift operation	19
Overview equipment options	20

---







































## COPYRIGHT & DISCLAIMER

The content of these planning guidelines – particularly text and graphics – are protected by copyright. Unless indicated otherwise, copyright is held by Lödige Industries GmbH.

The content of this document must not be published without the express consent of Lödige Industries GmbH. We reserve the right to make technical changes.

## PRODUCT FINDER

Which criteria are critical with regard to your goods lift?  
Choose from the criteria listed below.

	SHERPA®	ESCORTA®	OLYMPUS
Trained attendant	X		
Self-supporting shaft			X
Cabin size			
Use with forklifts	X	X	
Max. nominal load			
Min. pit			
Min. shaft head			
Shaft width/shaft depth			
Max. door width			
Machine control cabinet/room size			
Max. lifting speed			
Fire protection			
Connection current values			
Operating costs			

### Note on speed:

The goods lift ESCORTA® with trained attendants is certificated in accordance with Machinery Directive 2006/42/EC, in line with this, the maximum nominal speed is limited to 0.15 m/s.

X = not possible



= suitable



= well-suited



= very well-suited

## PRODUCT DESCRIPTION

SHERPA® and ESCORTA® goods lift - machine-room-less chain lift for low and medium height buildings with integrated shaft for the transportation of goods with or without attendant.

- Fast and easy installation
- Bespoke cabin sizes
- With and without trained attendants
- Self-supporting steel shaft
- No separate machine room necessary
- Ramp option available
- No pit necessary
- Type certificated after machine directive 2006/42/EC

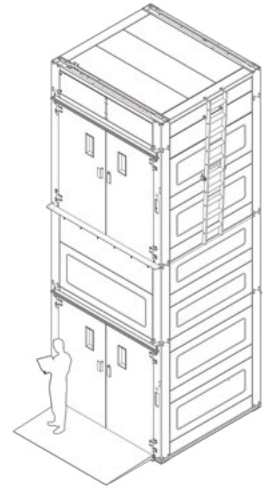
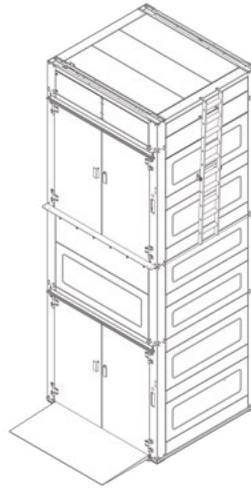

	SHERPA®	ESCORTA®
Payload	500 to 3,000 kg	
Lifting speed	0.2 - 0.4 m/s	0.15 m/s
Axle/edge load	60 % of the payload	
Number of stops	2 to 6	
Entrances	2 to 12	
Lifting height	up to 18 m	
Cabin width	900 - 2,800 mm	
Cabin depth	1,200 - 3,000 mm	1,600 - 3,000 mm
Cabin height	1,800 - 2,800 mm	
Shaft width	1.270 - 3.250 mm	
Shaft depth	1,340 - 3,180 mm	1,740 - 3,180 mm
Pit or ramp height	70 - 130 mm	
Door arrangement	One side loading or through car loading	
Power unit	Electric with chain	
Passengers	Not allowed - goods only	Trained attendant allowed
Directive	Certificate of conformity after machine directive 2006/42/EC	Type certificated after machine directive 2006/42/EC

## APPLICATION AREAS

---

The SHERPA® and ESCORTA® goods lifts are a cost-effective, efficient solution and can be used for a variety of applications. The quick and easy installation does not require any construction modifications and enables uninterrupted day-to-day operations even during assembly.



LOGISTICS AND DISTRIBUTION

The SHERPA® and ESCORTA® goods lifts are ideally suited for use in distribution and logistics companies and can be easily integrated into existing shelving systems and mezzanine levels.



PRODUCTION

In production facilities, goods can be transported between different levels more quickly and efficiently, thus greatly simplifying and improving process flows.



PUBLIC BUILDINGS

Whether exhibits, archive files or supplies – with our goods lifts, a quick and safe transport is ensured without affecting visitor traffic.



HOSPITALS & MEDICAL FACILITIES

Medical supplies, clean laundry and groceries are delivered daily. A centrally located passenger or bed elevator is often not sufficient. Our goods lifts are a sustainable solution for optimising logistics.



OFFICE BUILDING

In office buildings, the use of goods lifts can significantly relieve and safeguard the existing passenger lifts while increasing the attractiveness of rental space by making the transport of furniture and equipment easy.



HOTELS

Thanks to the fast and safe transportation of everyday necessities, waste and laundry away from the guests, our goods lifts can make a fundamental contribution to a positive visitor experience.

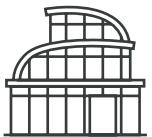

EVENT AND SHOPPING CENTRES

The installation of our SHERPA® and ESCORTA® goods lifts permanently enables the fast and safe transport of consumer goods and food between delivery and sales areas.

## BIM-CONFIGURATOR

Using our online BIM-Configurator, architects and planners can easily design the SHERPA® and ESCORTA® goods lifts in 2D or 3D, create dimensional drawing, data sheets and of course BIM-models in various file formats. You enter the suitable load capacity, the required number of stops and the configuration of the accesses. For your subsequent first planning steps, 2D and 3D models of your configura-

tion can be downloaded and inserted directly into your construction plans to the right scale. There are several file formats available for this: 2D & 3D DWG, 2D & 3D DXF, REVIT and IFC. Subsequently, you will receive a confirmation email from us with a summary of your configuration and your contact person for further information.

[Link to the BIM-Configurator](#)

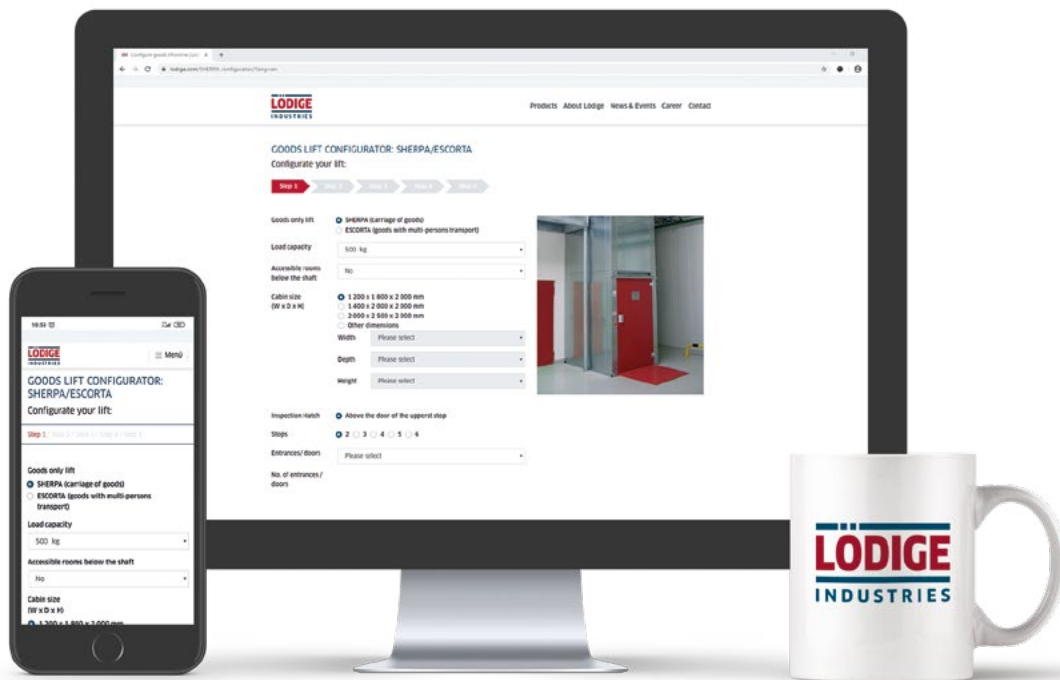

## LOAD CAPACITY

Our SHERPA® and ESCORTA® goods lifts are available as standard with a load capacity (nominal load) of 500 kg to 3,000 kg. The load capacity determines the dimensions of the elevator shaft and the cabin size (car width and car depth).

Since our goods lifts are type-tested according to the Machinery Directive 2006/42/EC, the minimum required load capacity is determined as 200 kg per square meter of cabin area. This means that for lifts with a low nominal load e.g. 500 kg the cabin area (width x depth) is limited to 2.5 m<sup>2</sup>. If you need a larger cabin area e.g. with a cabin

width of 2.8 m and cabin depth of 3.0 m (8.4 m<sup>2</sup>), the minimum required nominal load of the goods lift is 1,680 kg. This increases the safety of goods lifts and by ensuring cabin size and load capacity are in a safe and sensible relation to each other.

When configuring our SHERPA® and ESCORTA® goods lifts with our online configurator, this is automatically taken into account when determining cabin dimensions. If necessary, the configurator advised you to increase the nominal load or reduce the cabin dimensions.

## LIFT SHAFT

The SHERPA® and ESCORTA® goods lifts have a self-supporting steel frame shaft with sheet metal cladding. This is included in the scope of delivery as standard, so for elevators without fire protection no separate wall or concrete shaft is required. The shaft is fastened with heavy-duty anchors at the base of the lift shaft during assembly. Depending on the lifting height, fasteners may still be necessary on other floors. However, these do not introduce any static loads into the levels and only secure the system against forces that act on the system from the outside such as impact loads and wind loads.

If there are accessible rooms below the elevator shaft, the shaft pit must be able to absorb a surface load of 5,000 N/m<sup>2</sup>. Furthermore, in this case the elevator car is always equipped with a safety device. The ceiling opening dimensions as well as the shaft pit dimensions must be 40 mm larger on site than the shaft dimensions of the goods lift.

The lift shaft is not waterproof and weatherproof. Outdoor use is still possible if the shaft is adequately protected by weatherproofing measures, such as a canopy over the entrance and drainage systems. If the lift is to be used externally, please contact us for more information. The robust and reliable double-walled shaft swing doors (single or double-leaf) are used as the end of the lift shaft. A door

flap above each shaft door, which holds the door shut in an unlocked state and prevents it from being opened unintentionally.

An inspection hatch is integrated above the door of the top landing provides access to the drive in the event of maintenance or emergency release. The area in front of the inspection hatch and door flap (door height + 150 mm) must always be kept clear, as this is essential for the smooth operation of the goods lift. A clearance of at least 700 mm in depth must be provided in front of the inspection hatch and the control cabinet.

The lift shaft is made of bent, sendzimir galvanized sheet steel and is therefore already adequately protected against corrosion. Upon customer request, the lift shaft can also be supplied in a powder-coated version. All Classic Standard RAL colors are available, with the exception of metallic and luminous colors. Thanks to the innovative and compact modular sheet metal construction shaft or goods lifts can be assembled quickly even in limited spaces. The shaft of the SHERPA® and ESCORTA® is shown below using a two-stop elevator with shaft pit and front-only access on all levels.

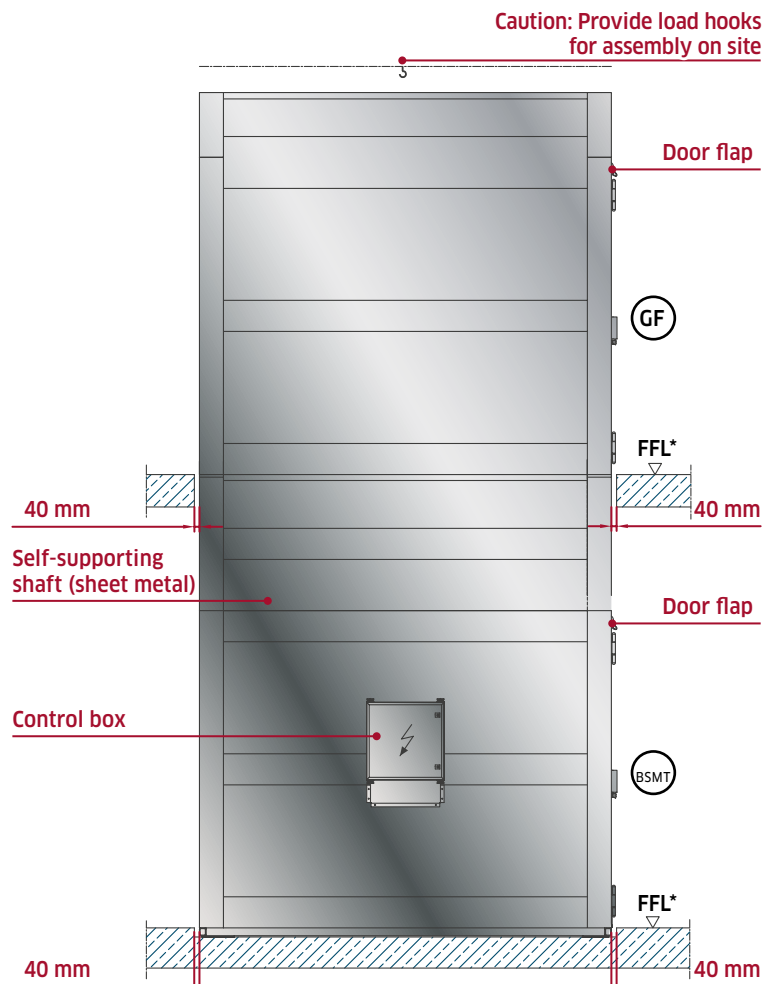
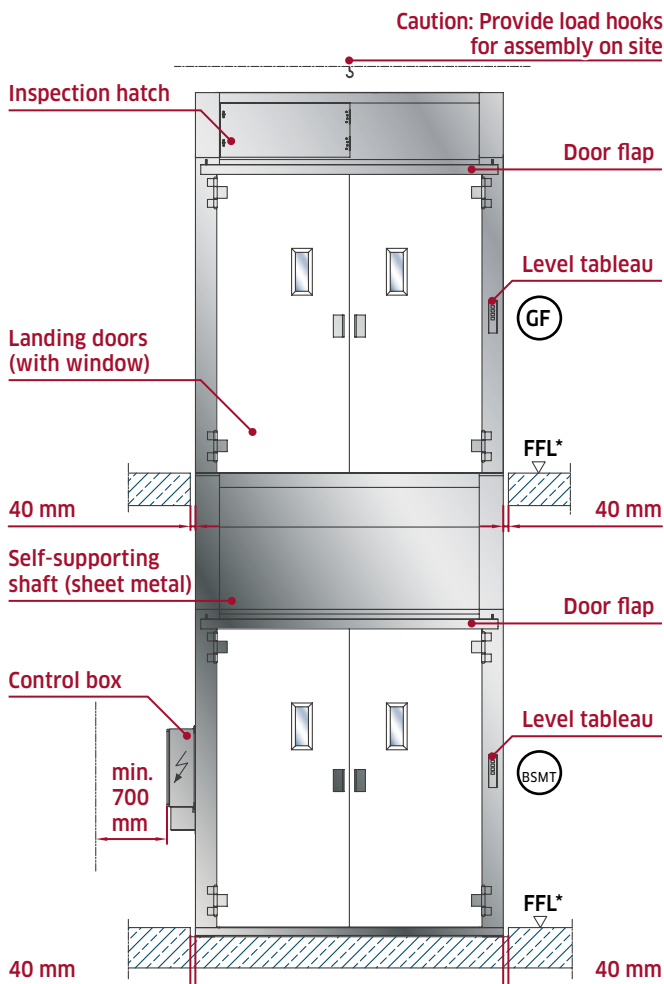

FFL\* = Finished floor level

## LIFTING HEIGHT

The entire travel distance of the lift car is called the lifting height. For goods lifts with a pit, the lifting height is calculated from the upper edge of the finished floor level (FFL) of the lowest stop to FFL of the highest stop. For goods lifts using a ramp instead, the lifting height is calculated from the top edge of the ramp to FFL of the top floor the top stop.

The lifting height is relevant for the technical design of the lift and for the calculation of the shaft dimensions, such as shaft width, shaft depth, shaft height and shaft head room. For a relevant quote, the lifting height, the number

of stops and the number and configuration of entrances are required. The maximum lifting height of the SHERPA® and ESCORTA® goods lifts is 18 m. The minimum lifting height between individual floors depends on the arrangement of the entrances. It depends on whether the doors are front-only or through car access and your maximum nominal load.

The SHERPA® and ESCORTA® goods lifts below show an example with a pit and one with a ramp to explain the difference in the lifting height measurement. The lift doors are used as a shaft closure at all stops.

Arrangement of the doors	Front-only access	Through car loading
Max. lifting height	18,000 mm up to 2,500 kg: door height + 300 mm	18,000 mm
Min. lifting height	from 2,501 kg: door height + 350 mm	450 mm

GOODS LIFT WITH A PIT

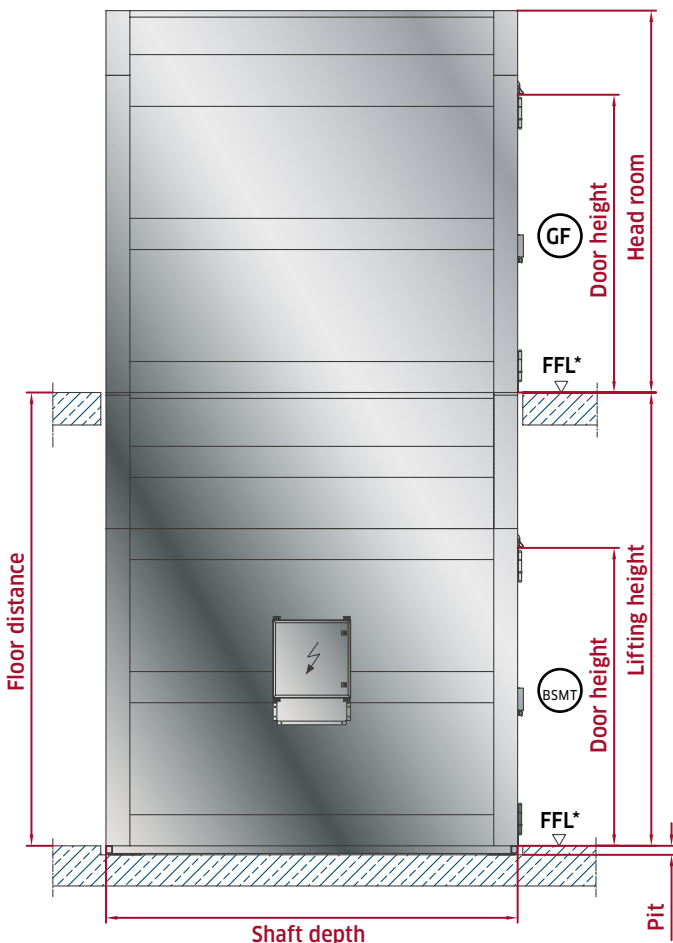

GOODS LIFT WITH A RAMP

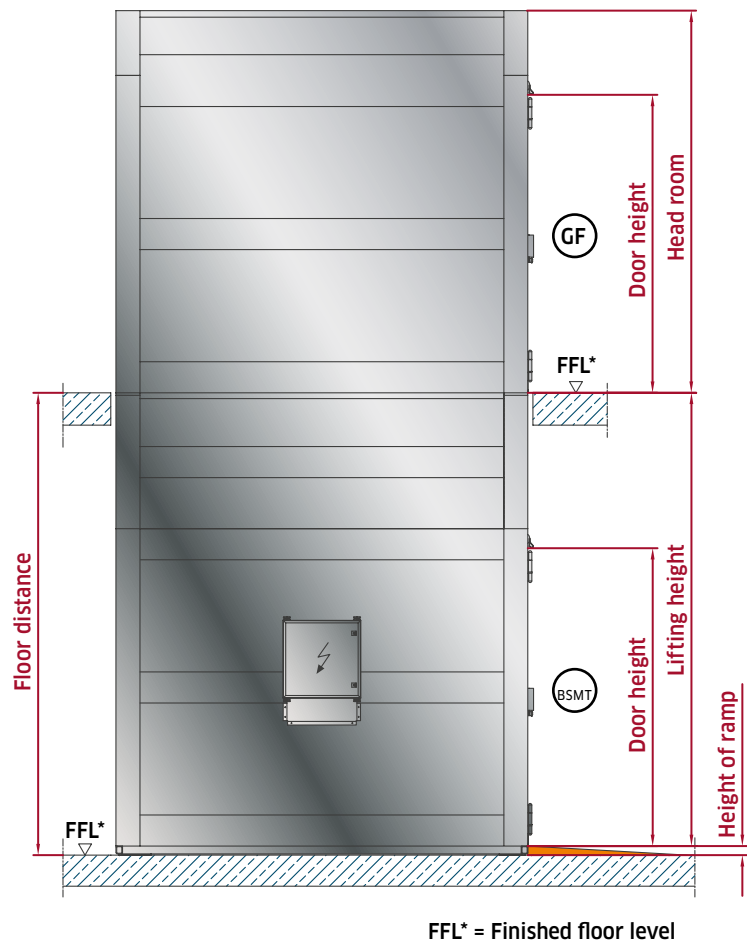

FFL\* = Finished floor level



## SHAFT WIDTH/CABIN WIDTH/DOOR WIDTH

The larger the cabin width, the easier it is for the user to comfortably and safely move goods in and out. For the SHERPA® and ESCORTA® goods lifts, the clear door width always corresponds to the selected clear cabin width. The term *car width* describes the clear distance between the inner side walls of the lift car.

Since the lift shaft is always part of the goods lift, the shaft width is determined by the car width and the load capacity. The table below shows several nominal load classes. Cabin widths from 900 mm to 2,800 mm are possible with our goods lifts, depending on the selected nominal load

(see section *Load capacity*). For your first planning steps, you can use the following table as a guide, which shows frequently requested dimensions. The information applies to a maximum delivery height of 18 m. After selecting the cabin width our online configurator automatically determines, the shaft width in and applies them to the 2D drawings and 3D models.

We can adapt cabin dimensions (width, length and height) of our goods lifts to your requirements. We will be more than happy to provide specialised solutions for your project.

Load capacity	Up to 2,500 kg	From 2,501 kg
Cabin width	900 – 2,800 mm	
Door width	Corresponds to the clear cabin width	
Shaft width	Door width + 370 mm	Door width + 450 mm
Width ceiling breakthrough	Door width + 450 mm	Door width + 530 mm

FRONT-ONLY ACCESS

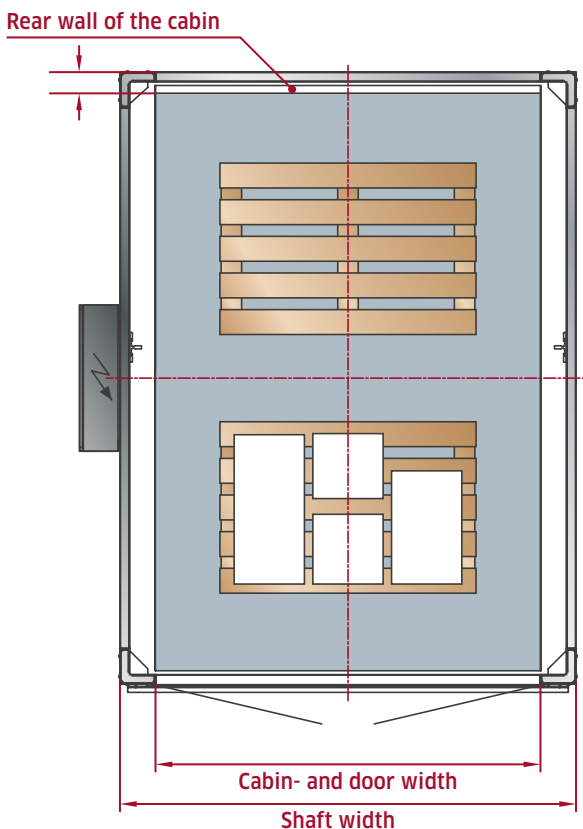

THROUGH CAR ACCESS

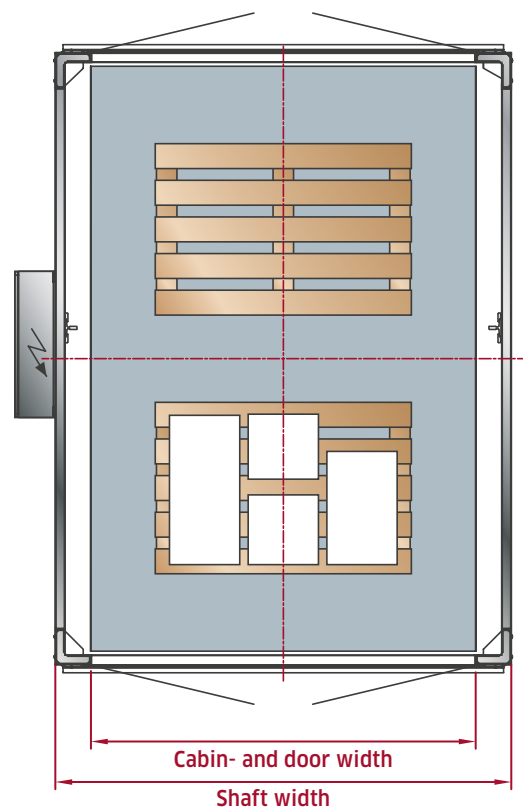

## SHAFT DEPTH/CABIN DEPTH

The SHERPA® and ESCORTA® goods lifts are available in cabin depths from 1,200 mm to 3,000 mm. The arrangement of the shaft doors (front-only or through car access), the nominal load and whether or not attendants are to be transported impact the cabin depth required.

When the shaft doors are arranged on one side, the term *car depth* describes the clear distance between the edge of the platform in the door area and the rear cabin wall. With opposite doors (through-car), the term *car depth* describes the clear distance between the outer platform edges of the lift car.

Furthermore, a distinction must be made between the SHERPA®, the variant without trained attendants, and the variant with trained attendants, the ESCORTA®. With the ESCORTA®, the minimum cabin depth is always 1,600 mm. With the SHERPA®, a minimum cabin depth of 1,200 mm is possible. Above 1,500 kg load capacity, the minimum cabin depth of the SHERPA® is 1,400 mm and 1,600 mm from 2,000 kg. Above 2,501 kg, the minimum cabin depth

is 1,800 mm. If there are accessible rooms below the elevator, a safety device must be used, which requires a minimum cabin depth of 1,600 mm.

Since the elevator shaft is always part of the goods lift, the shaft width depends on the choice of car depth, the nominal load and the configuration of the doors. If doors are only on one side of the shaft, then a rear cabin wall is used. The shaft depth then increases by the thickness of the rear wall of the cabin.

In general, we can adapt our goods lifts in terms of cabin dimensions (width x length x height) to your different requirements. We would also be happy to work out special solutions for you. For your first planning steps, you can use the following table as a guide, based on frequently requested dimensions. The information applies to a maximum delivery height of 18 m. In our online configurator, the shaft depth is automatically determined, after selecting the cabin depth, and taken into account in the 2D drawings and 3D models.

		SHERPA®	ESCORTA®
Cabin depth (min. - max.)		1,200 - 3,000 mm	1,600 - 3,000 mm
Min. cabin depth	up to 1,500 kg load capacity	1,200 mm	1,600 mm
	from 1,500 kg load capacity	1,400 mm	1,600 mm
	from 2,000 kg load capacity	1,600 mm	1,600 mm
	up to 2,500 kg load capacity	1,600 mm	1,600 mm
	from 2,501 kg load capacity	1,800 mm	1,800 mm
Min. shaft depth	front-only access up to 2,500 kg load capacity	cabin depth + 180 mm (+ 260 mm*)	
	front-only access from 2,501 kg load capacity	Cabin depth + 180 mm (+ 260 mm*)	
	through car access up to 2,500 kg load capacity	cabin depth + 140 mm (+ 220 mm*)	
	through car access from 2,501 kg load capacity	Cabin depth + 140 mm (+ 220 mm*)	

\*Depth of ceiling breakthrough

## SHAFT DEPTH/CABIN DEPTH

FRONT-ONLY ACCESS

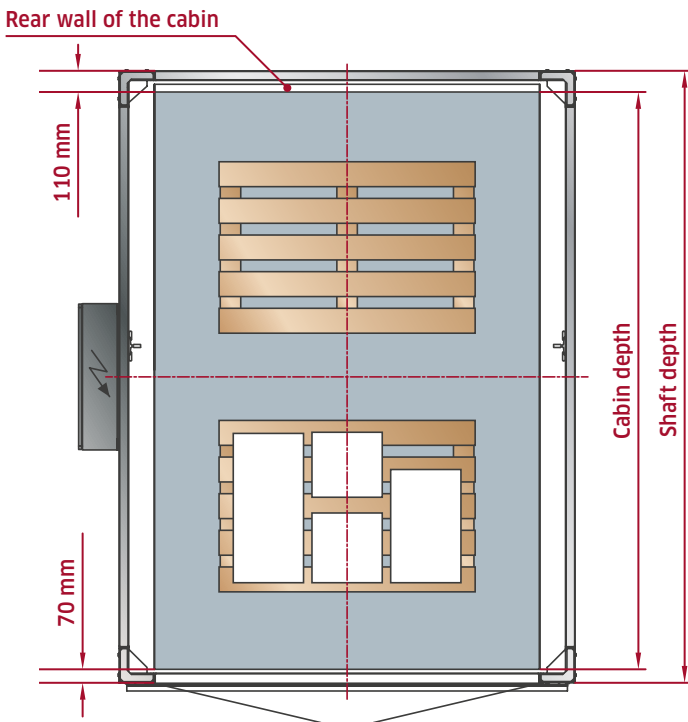

THROUGH CAR ACCESS

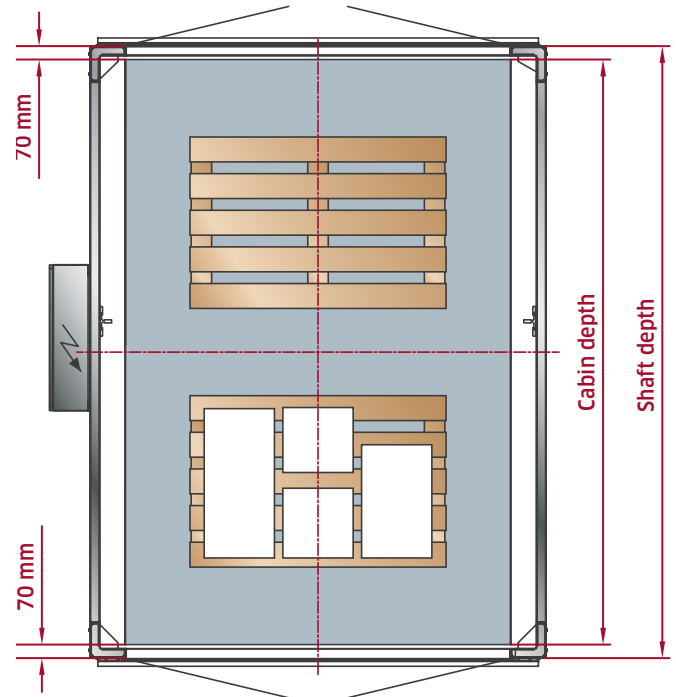

## SHAFT HEAD/CABIN- AND DOOR HEIGHT

The clear cabin height always corresponds to the clear door height. Cabin and door heights from 1,800 mm to 2,800 mm are possible. The cabin height and door height are independent of the nominal load. The shaft head (headroom) refers to the space between the top edge of the finished floor level (FFL) of the top landing to the top edge of the lift shaft. The total height of the shaft head depends on the selected cabin and door height plus a variable. The variable depends on the maximum nominal load, cabin size and the design of the shaft end doors according to EN 81-58. For nominal loads of up to 2,000 kg, the variable dimension for the height of the shaft head ranges

between 450 mm and 650 mm for our SHERPA® and ESCORTA® lifts. For nominal loads of 2,001 kg and above, this is always 650 mm. When configuring a goods lift, with our online configurator, the correct height of the shaft head, including the variable, is automatically calculated and automatically utilised in the drawings and models provided for you.

For the assembly of the SHERPA® and ESCORTA® goods lifts a free assembly space of 400 to 500 mm is required above the elevator shaft. This dimension can be reduced on request.

Up to 2,000 kg load capacity

From 2,001 kg load capacity and fire protection

Shaft head

Door height + (450 or 650 mm)

Door height + 650 mm

## SHAFT HEAD/CABIN- AND DOOR HEIGHT

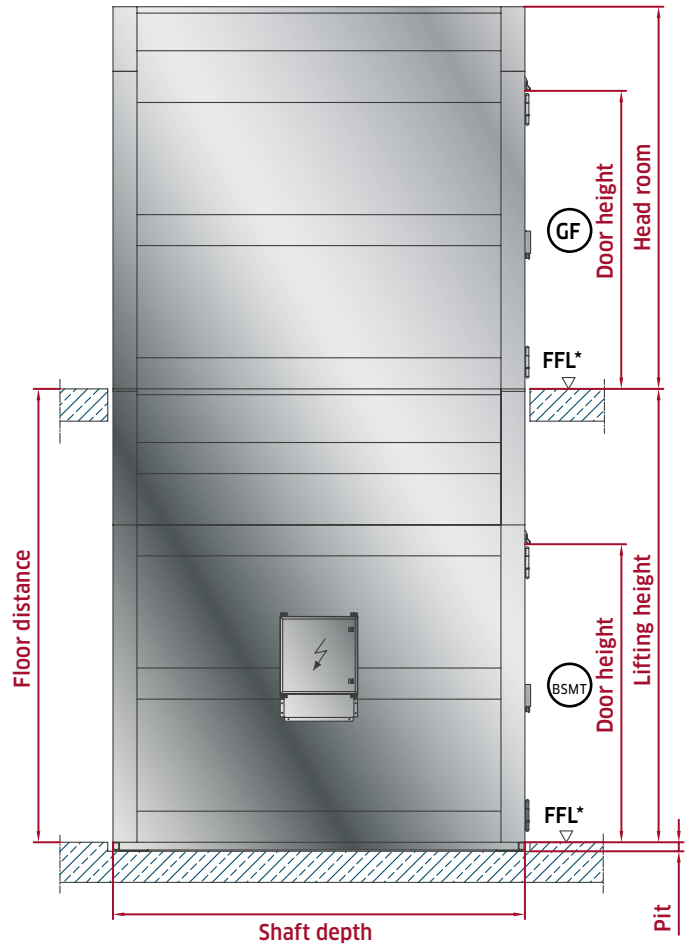
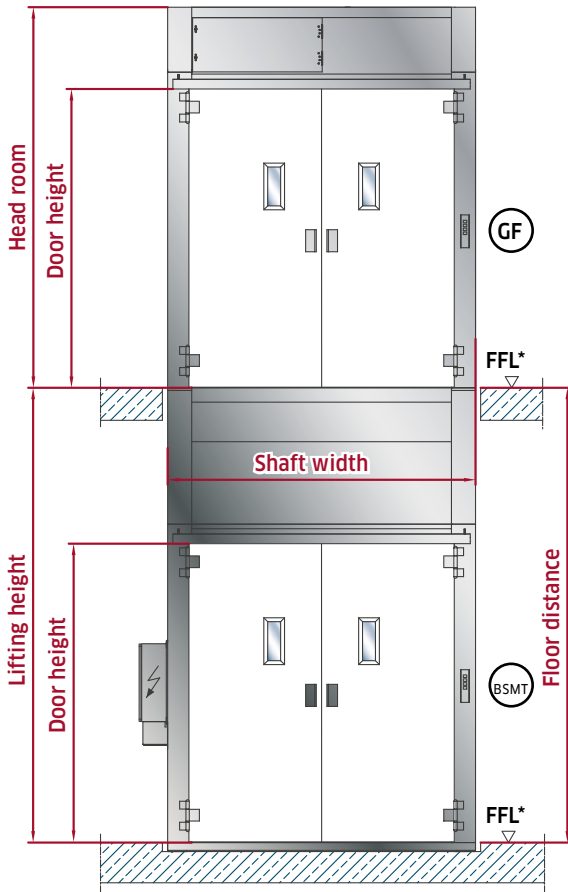

Note on cabin and door height:  
The clear cabin height always corresponds to the clear door height.

FFL\* = Finished floor level

## PIT/RAMP

Depending on the customer's requirements, a shaft pit or a ramp can be used on the lowest level for the SHERPA® and ESCORTA® goods lifts. The shaft pit is measured from the top edge of the finished floor (FFL) of the bottom stop to the top edge of the bottom of the lift shaft. The height of the ramp is the measure from the top edge of the finished floor level (FFL) of the bottom stop to the top edge of the threshold of the bottom stop. The depth of the pit

or height of the ramp ranges between 70 and 130 mm and depends on the nominal load of the goods lift. The table below shows the pit depth and the height and length of the ramp depending on the nominal load. For nominal loads between 2,000 and 2,500 kg, the depth of the pit or the height of the ramp varies between 90 and 110 mm. To keep the slope angle of the ramp as small as possible, the length varies based on the height of the ramp.

Payload	Pit depth/ramp height	Length of the ramp
up to 1,999 kg	70 mm	1,000 mm
2,000 to 2,500 kg	90 - 110 mm	1,000 - 1,500 mm
2,501 to 3,000 kg	130 mm	1,500 mm

## SHAFT DOORS/FIRE PROTECTION

At each landing, we use robust, reliable and decades proven double-walled shaft swing doors. Our shaft landing doors are single or double leaf swing doors that are equipped with a door lock according to EN 81-20. The doors are primed in RAL 7032 (pebble grey) as standard. Furthermore, all standard RAL Classic colours, with the exception of metallic and neon colours, are available for the swing doors.

If fire protection is required in your planning, SHERPA® and ESCORTA® goods lifts doors can be deliver compliant with EN 81-58. Depending on the requirements, various performance criteria such as space enclosure (E), thermal insulation (I) and radiation (W) with corresponding classification times can be selected for the shaft doors. As standard, our shaft end doors have an approval according to EN81-58 with the classification E120, EI05, EW30

or E120, EI15, EW60. This means that the goods lift can be installed in a fire-resistant shaft on site according to DIN 4102 (EN 13401-1). The steel shaft is attached to the on-site fire-resistant shaft using brackets. In front of the inspection hatch, a separate inspection hatch must be installed in the fire-resistant shaft on site in accordance with the fire protection regulations, which ensures both the fire protection requirement and the accessibility to the inspection hatch.

It is also possible to equip the lift doors with door dampers. These buffer the individual door leaves during the closing process so that noises are avoided when the doors slam shut. Furthermore, a door damper protects the door and the door hinges. The door closes fully. Door dampers are nor classified as fire-resistant under EN 81-58.

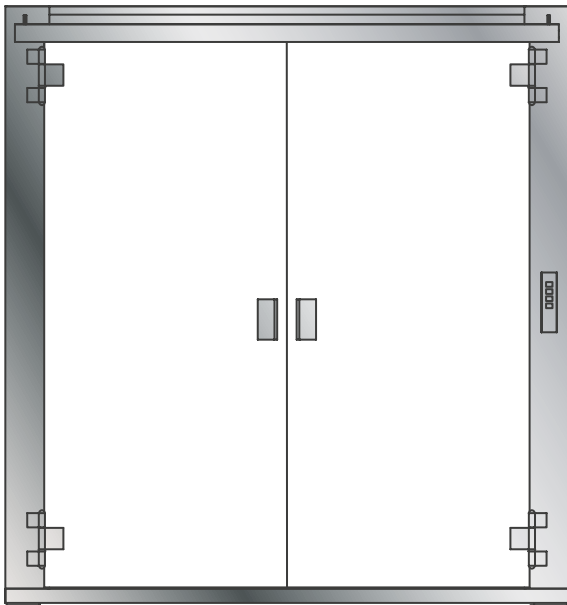

### SHERPA®

- Without viewing window as standard
- Fire protection according to EN 81-58 possible
- No door handle shells on the inside of the doors
- Single-leaf doors possible up to a cabin width of 1,500 mm
- Double-wing doors are a must for cabin widths above 1,500 mm

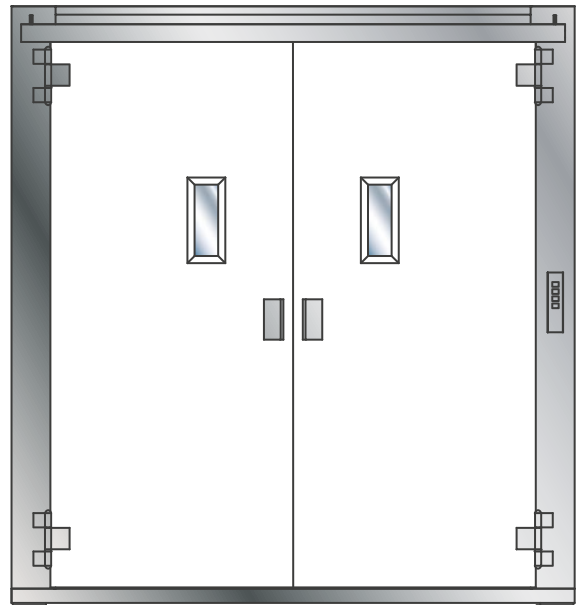

### ESCORTA®

- Always with a viewing window
- Fire protection according to EN 81-58 possible
- Always with door handle shells on the inside of the doors
- Single-leaf doors possible up to a cabin width of 1,500 mm
- Double-wing doors are a must for cabin widths above 1,500 mm

## LIFT CABIN

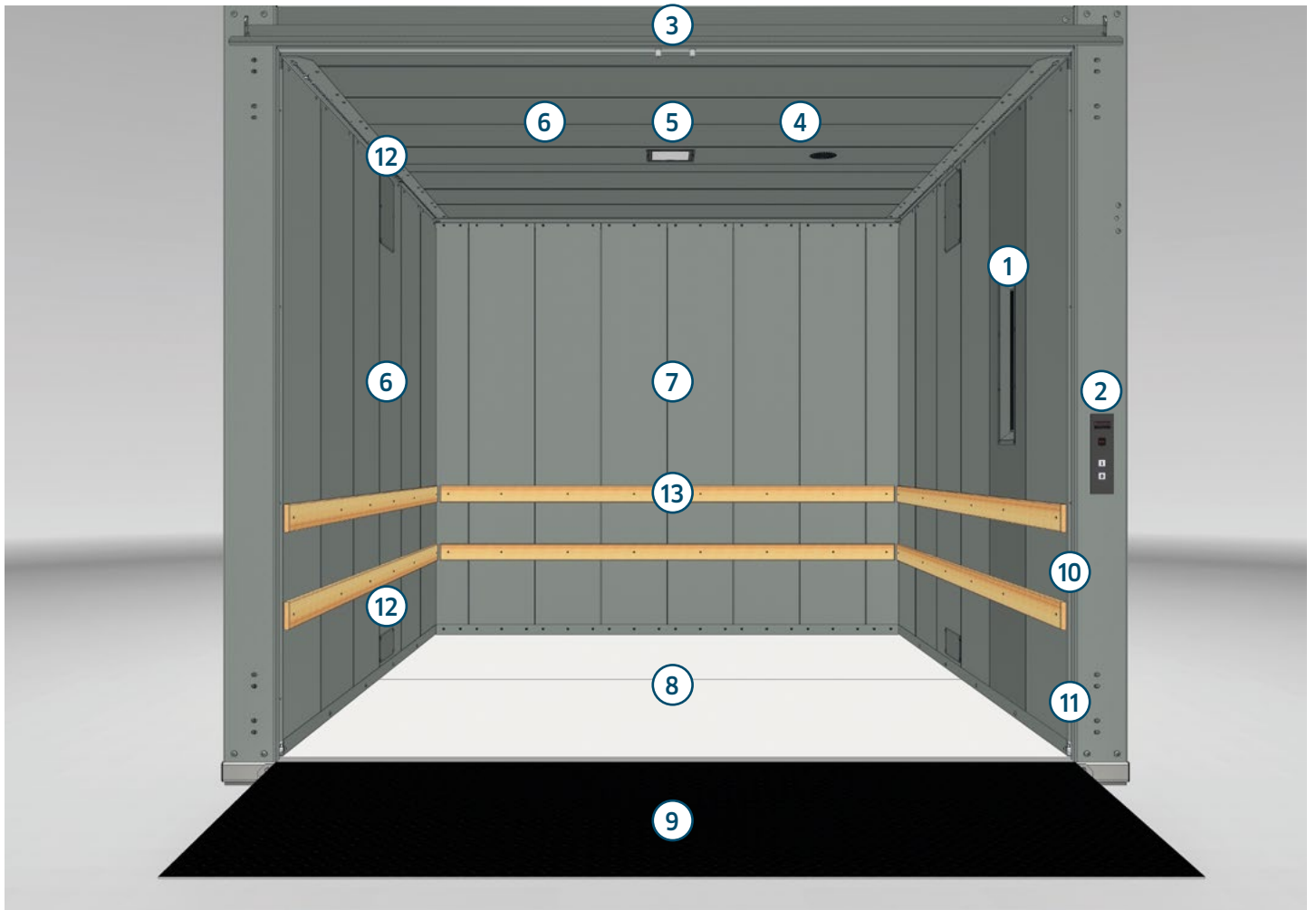

ESCORTA® with ramp and rear wall (front-only access)

### LEGEND

- |  |   |
|--|---|
| 1. Cabin operating panel (COP)*            | 8. Cabin floor                          |
| 2. Landing Operating Panel                 | 9. Ramp (optional)                      |
| 3. Door flap                               | 10. Light curtain at the entrance*      |
| 4. Auto-dialler speaker & Microphone*      | 11. Fixing points for the landing doors |
| 5. Cabin lighting LED-Panel (optional)     | 12. Service access panels               |
| 6. Cabin ceiling/cabin walls               | 13. Bump rails (optional)               |
| 7. Cabin rear wall (for front-only access) |   |

\*Only for ESCORTA®

## LIFT CABIN

### 1. CABIN OPERATING PANEL (ONLY FOR ESCORTA®)

As the Sherpa does not allow trained attendants, cabin operating panels are only used for the ESCORTA® goods lift.

Only one cabin panel is provided, recessed in the cabin side wall, of the ESCORTA®. The cabin panel is made of stainless steel and integrated in the left or right-side wall of the cabin. The cabin control panel includes an overload indicator (1), a travel indicator (2), illuminated pushbuttons for floor selection and displays (3), auto-dial buttons (4) and an emergency stop push-button (5). Upon customer request, a key switch (6) or preparation for an on-site card reader is available to limit the number of users.

In the SHERPA®, an acoustic overload indicator is only installed for nominal loads above 1,000 kg. In the event of an overload, a warning tone is emitted via a signal horn integrated in the shaft.

To move to the desired floors, the destination button must be pressed and held over the entire journey (jog mode).



### 2. LANDING OPERATING PANEL (LOP)

LOPs in SHERPA® and ESCORTA® goods lifts are made of stainless steel and can be arranged either to the left or to the right of the door. In the case of single-leaf doors, the panel is ergonomically located on the side of the door handle.

The LOPs are equipped with a busy display (1) and call-send button (2). If the doors are open or the car is in motion, the busy indicator lights up and the current position of the car is shown on the level indicators.

Use of a key switch or on-site card reader for a trained group of users is possible. Since our goods lifts are always equipped with a call and send control, the lift car can be called or sent to the respective floor desired with the help of the landing call button (2).

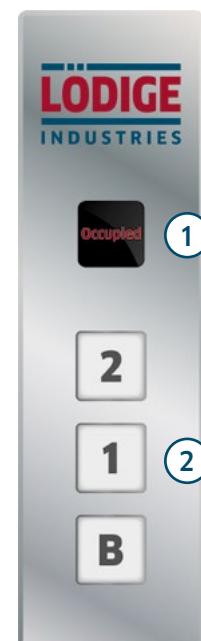

## LIFT CABIN

---

### 3. DOOR FLAP

---

A door flap is installed above each shaft end door. It prevents the door from opening unintentionally when unlocked. The door flap also monitors the status (open-closed) of the door. The position of the elevator car is

detected at all times by additional sensors in the shaft. The elevator door can only be unlocked/opened when the car is on the respective floor. The area in front of the door flap must always remain free.

### 4. AUTO-DIALLER

---

Due to the possibility of attendants in the ESCORTA® goods lift, an emergency call device is always integrated. In an

emergency, the auto-dialler device can be operated via the cabin panel. The intercom is located in the cabin ceiling.

### 5. CABIN LIGHTING LED-PANEL

---

A square energy-saving LED panel is built into our ESCORTA® goods lift. The LED panel in the car ceiling ensures high-quality and long-lasting lighting, reduces energy consumption and has ten times the lifespan of a conventional fluorescent lamp. The light colour is 840,

neutral white, colour temperature 4000 K. Each LED panel has an output of 18W and a luminous flux of 1200 lm. Lighting is optional for our SHERPA® goods lift in conjunction with a cabin ceiling.

### 6. CABIN CEILING/CABIN WALLS

---

The cabin walls as well as the cabin ceiling are made of galvanised steel sheet and designed in a lamella construction. The structure and galvanizing offer sufficient protection from external influences. A powder-coated version

of the cabin is available on request in combination with powder-coated doors. The cabin ceiling is always designed as non accessible. The cabin ceiling is optionally available for SHERPA® goods lift.

### 7. CABIN REAR WALL

---

If the stops of the goods lift are arranged on one side only (front-only access), the elevator car will be equipped

with a car rear wall. The rear wall finish is in line with the other cabin walls.

### 8. CABIN FLOOR

---

The cabin floor of the SHERPA® and ESCORTA® goods lift is made of smooth sheet metal with a two-component anti-slip coating. The two component anti-slip coating is an epoxy resin-based, solvent-free and non-slip coating in RAL 7040. Further versions are available on request, e.g.

steel tear plate (painted in door colour) or aluminium tear plate possible. For goods lifts up to max. 1,000 kg nominal load and max. 1,400 mm cab width galvanised platforms are standard.



## LIFT CABIN

---

### 9. RAMP (OPTIONAL)

---

In lieu of a shaft pit, an access ramp can be used at the lowest floor. The height and length of the ramp vary depending on the load capacity of the goods lift (see section *Pit/ramp*). Generally, the ramp is made of chequered plate

metal and is painted or primed in the same colour as the elevator door. Of course, other classic RAL colours as well as a side bevel are possible on request.

### 10. LIGHT CURTAIN IN THE ENTRANCE

---

Since several escorts are possible with the ESCORTA® goods lift and cabin doors are dispensed with due to the compact design, additional high-performance safety edge

sensors (min. 2 m) are used in the access area. This means that all accompanying persons are adequately protected at all times.

### 11. FIXING POINTS FOR THE LANDING DOORS

---

Lift doors are attached to the side of the door frame with two door hinges per door leaf. The doors are available with fire protection according to DIN EN 81-58 as well as

in all standard Classic RAL colours. Further information as well as a representation of the elevator doors in the closed state can be found in the section *Elevator doors*.

### 12. SERVICE ACCESS PANELS

---

Two maintenance access panels are installed on each side wall of the elevator car. Our Lödige service team

can use these to carry out various maintenance and service work.

### 13. BUMP RAILS (OPTIONAL)

---

Upon request, bump rails made of hardwood or plastic are available in 1-row or 2-row versions for our lift cars. The hardwood rails are 100 mm high and 20 mm thick. Plastic rails are available in white, black or green and are 150 mm high and 15 mm thick. Standard position of the lowest deflector strips is normally 250 mm from the platform

floor (to lower edge of rail) and that of the uppermost (in the case of a two-row version) is 550 mm from the platform floor. The position can be changed to suit your requirements. Furthermore, the bump rails in the access area are chamfered over the entire thickness, so do not catch during loading.

## CONTROL CABINET

The control cabinet of the SHERPA® and ESCORTA® goods lifts is generally attached directly to the shaft. A separate machine room is not required for our goods lifts. The control cabinet can be mounted on the left or right of the lift shaft on each floor. If desired, the control cabinet can also be moved away from the lift shaft and attached to a nearby wall, max. 10 m from the shaft. The area in front of the control cabinet must always be kept clear. A free space of

at least 700 mm in depth over the width of the control cabinet is needed to allow for maintenance access. The control cabinet is painted in RAL 7035 and has the IP protection IP54 without a frequency converter (FC), with a FC IP44.

The size of the control cabinet depends on the equipment of the goods lift. Size ranges of the control cabinets are shown below.

	Control cabinet of SHERPA®	Control cabinet of ESCORTA®
Height	600 – 760 mm	760 mm
Width	600 – 760 mm	760 mm
Depth	210 mm	210 mm

### CONTROL CABINET ON SHAFT

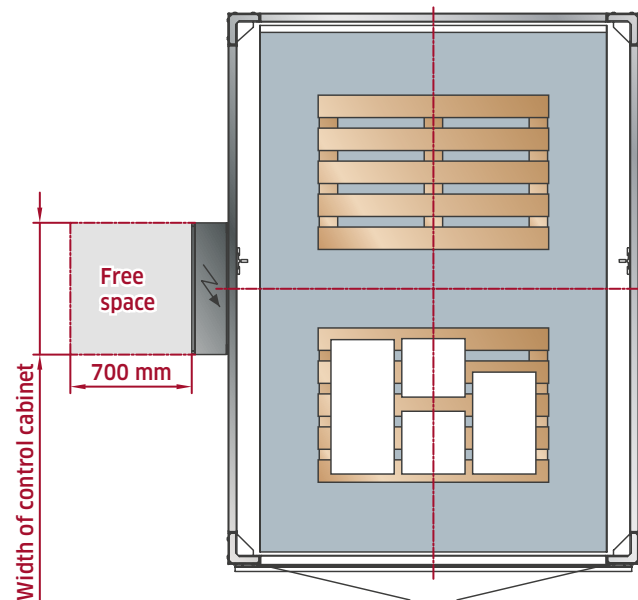

### CONTROL CABINET ON WALL

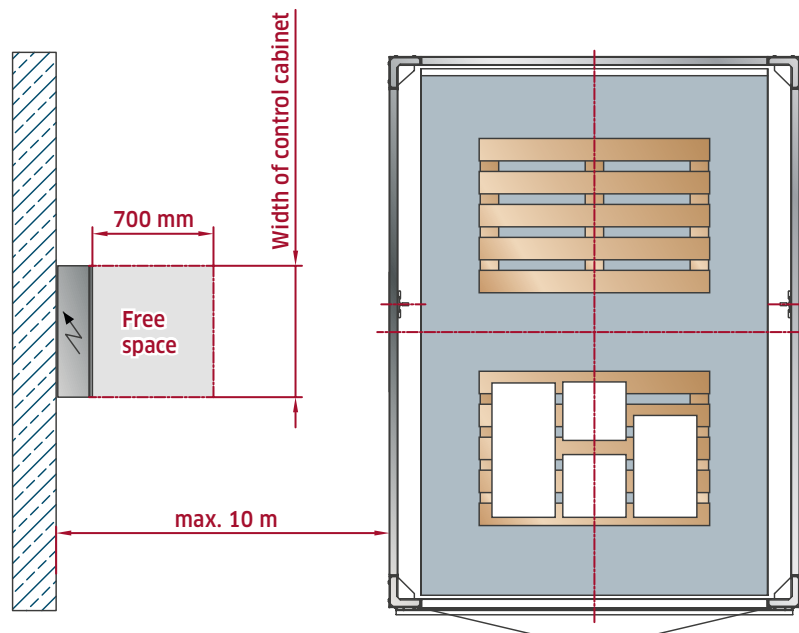

## DRIVE TYPE

The SHERPA® and ESCORTA® goods lifts are designed for a load capacity of up to 3,000 kg. An electric parallel shaft geared motor with single-circuit (SHERPA®) or double-circuit brake (ESCORTA®) is used as the drive. The suspension elements are two roller chains. The complete drive unit is located in the shaft head. This enables a very compact and almost maintenance-free construction.

On request, a frequency inverter can be used in both SHERPA® and ESCORTA® goods lifts. This is particularly advisable for comfort, jolt-free and soft starting and stop-

ping when transporting accompanying persons, as well as reducing car movement during loading. In certain applications, such as those with high nominal loads, nominal speeds, delivery heights, with fragile or liquid loads, the use of a frequency inverter is necessary. We would be happy to advise you on your project in this regard.

The size of the drive depends on the load capacity, the cabin dimensions and the nominal speed and can therefore vary widely.

	<u>Lifting height</u>	<u>Lifting speed</u>	<u>Motor power</u>	<u>Current nominal flow*</u>	<u>Current initial flow***</u>
<u>SHERPA®</u>	up to 18,000 mm	0.2 m/s**	2,5 – 13,5 kW	5,5 – 22 A	12,8 – 56,3 A
<u>ESCORTA®</u>	up to 18,000 mm	0.15 m/s	2,5 – 11 kW	5,5 – 19 A	

\* electricity at full load

\*\* country-specific guidelines must be observed

\*\*\* with frequency converter

Special designs on request, technical changes possible, ESCORTA® always 0.15 m/s, drive size depending on the nominal load, cabin dimensions and nominal speed.

## LIFT OPERATION

Both SHERPA® and ESCORTA® goods lifts are equipped with a call and send control. On each floor, the lift can be called using the control panel. Since it is forbidden for people to travel with the SHERPA®, no control panel is installed inside the elevator car.

With the ESCORTA® it is allowed for several people to travel in the lift car, hence a control panel is installed in the lift car. The lift is designed for operation by a restricted and

instructed group of users, in an area that is not open to the public and is done in push and hold (dead man's control).

The user group can be restricted by using a key switch or card reader. However, this is only necessary if trained users will be accompanied by others. If the lift is only used by trained users, the key switch can be omitted.

## OVERVIEW EQUIPMENT OPTIONS

---

Various additional options can also be selected for our SHERPA® and ESCORTA® goods lifts. If you have any further requests regarding the equipment, please contact us.

### SHAFT

---

#### ***Pit and ramp***

You can choose between using a pit and a ramp at the bottom stop. Approach bevel made of steel teardrop plate is primed or painted in the same colour as the lift door. A side bevel is available on request.

#### ***Accessible rooms below the lift shaft***

If you have accessible rooms below the lift shaft in your building the use of a safety gear is mandatory in accordance with applicable standards. Pit loads must be taken into account on site.

#### ***Powder coating of the elevator shaft:***

A complete powder coating of the elevator shaft is possible on customer request. All common Classic RAL colors are available. Metallic and neon colors are not possible. This option also includes the powder coating of the landing doors.

#### ***LED – signal light for each access***

If requested, an LED surface-mounted light (red/green signal) can be attached to the side of the lift shaft or above the door. If the lift is in use, the red LED of the surface-mounted lamp lights up. If the lift is free, the green LED at the stop where the lift car is located lights up, all other levels show red.

### DOOR

---

#### ***Painting of the shaft doors***

The lift doors can be painted in all common RAL Classic colours on customer request. Metallic and neon colours are not possible.

#### ***Doors with door damper***

The door dampers reduce the closing noises and mechanical loads on the door leaves during the closing process. Furthermore, a door damper protects the door and the door hinges. It ensures, the door closes automatically to the last millimetre. Fire protection according to DIN EN

81-58 is no longer possible when using a door damper.

#### ***Swing shaft doors with window (SHERPA®)***

Optionally the SHERPA® can be equipped with windows (100 mm x 300 mm) in line with the ESCORTA®.

#### ***Fire doors***

The lift doors have fire protection according to EN 81-58. The following fire protection classes are available: With this option, the use of door dampers is not possible. The following fire protection classes are possible: E120, EI05, EW30 or E120, EI15, EW60.

### CABIN

---

#### ***Car ceiling***

Can optionally be ordered with the SHERPA® goods lift. Mandatory for car lighting

#### ***Auto-dialler system (only for ESCORTA®)***

Here you can choose between landline connection or two GSM modules: 2G or 4G (LTE).

#### ***LED cabin lighting***

SHERPA® goods lifts can be ordered with LED cabin lighting as an option. As with the ESCORTA®, an LED panel is integrated in the car ceiling. The use of a car ceiling is therefore absolutely necessary for this option. Without car lighting, the area in front of the entrances must be adequately illuminated, so we always recommend car lighting.

## OVERVIEW EQUIPMENT OPTIONS

---

### CABIN

---

#### ***Bump rails strips***

Upon request, cabin walls can be equipped with hardwood or plastic bump rails in single or double rows. Hardwood bump rails are 100 mm high and 20 mm deep. Plastic bump rails are available in white, green and black and are 150 mm high and 15 mm deep.

#### ***Load securing***

If desired, a roll-off protection, which that can be lowered into the cabin floor can be installed in the area of the doors. This reduces the available cabin depth by 175 mm.

#### ***Powder coating of the elevator car:***

A complete powder coating of the elevator car is possible on customer request. All common Classic RAL colors are available. Metallic and neon colors are not possible. This option also includes the powder coating of the landing doors.

#### ***Cabin floor***

The following versions of the cabin floor are possible on customer request:

- Steel chequered plate (painted in door colour)
- Aluminium chequered plate
- Two-component anti-slip coating possible
- Galvanised platform (only possible up to 1,000 kg nominal load and 1,400 mm cabin width)

The two component anti-slip coating is an epoxy resin-based, solvent-free and non-slip coating, in RAL 7040.

### POWER TRAIN

---

#### ***Frequency inverter***

The use of a frequency inverter is optional on our SHERPA® and ESCORTA® goods lifts. In certain applications, such as with high nominal loads, nominal speeds, delivery heights, with fragile or liquid loads, the use of a frequency inverter

is necessary or sensible. We would be happy to clarify this with you in a consultation and find the best solution for your application.

### STAINLESS STEEL

---

A stainless steel version of the SHERPA® and ESCORTA® goods elevator must be individually requested and clarified.

However, a design for clean rooms or according to hygiene regulations is not possible.

### SERVICE

---

Our freight elevators have a standard warranty period of 12 months. This includes 3 Service visits. In the first 3 months after delivery, the exact use and thus the maintenance frequency can be determined. During this period, our service department can make you an offer for a maintenance contract according to EN 13015.

Lödige Industries GmbH  
Wilhelm-Lödige-Str. 1  
34414 Warburg/Scherfede  
Deutschland

Tel. +49 5642 702-0  
info@lodige.com

[www.lodige.com](http://www.lodige.com)

